

## 1. Description

The KNX4820B-Channel enhancement mode silicon gate power MOSFET is designed for high voltage, high speed power switching applications such as high efficiency switched mode power supplies, active power factor correction, electronic lamp ballasts based on half bridge topology

## 2. Features

- n Proprietary New Planar Technology
- n  $R_{DS(ON),typ.}=250m\ \Omega@V_{GS}=10V$
- n Low Gate Charge Minimize Switching Loss
- n Fast Recovery Body Diode

## 3. Pin configuration

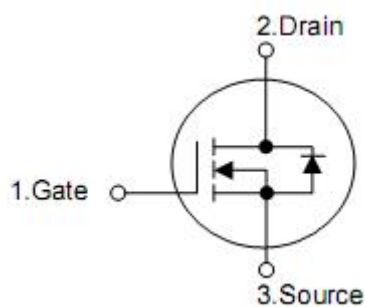
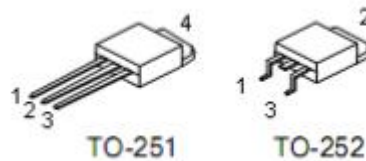

Pin	Function
1	Gate
2	Drain
3	Source
4	Drain

#### 4. Ordering Information

Part Number	Package	Brand
KNU4820B	TO-251	KIA
KND4820B	TO-252	KIA

#### 5. Absolute maximum ratings

TC=25°C unless otherwise specified

Parameter	Symbol	Ratings	Unit
		TO251/TO252	
Drain-to-Source Voltage	$V_{DSS}$	200	V
Gate-to-Source Voltage	$V_{GSS}$	±20	
Continuous Drain Current	$I_D$	9.0	A
Pulsed Drain Current at VGS=10V	$I_{DM}$	36	
Single Pulse Avalanche Energy	$E_{AS}$	300	mJ
Power Dissipation	$P_D$	83	W
Derating Factor above 25°C		0.59	W/°C
Maximum Temperature for Soldering Leads at 0.063in (1.6mm) from Case for 10 seconds, Package Body for 10 seconds	$T_L$	300	°C
Operating and Storage Temperature Range	$T_J$ & $T_{STG}$	-55 to 150	

*Caution: Stresses greater than those listed in the "Absolute Maximum Ratings" may cause permanent damage to the device.*

#### 6. Thermal characteristics

Parameter	Symbol	Ratings		Units
		TO251	TO252	
Thermal resistance, junction-ambient	$R_{\theta JA}$	75		°C/W
Thermal resistance, Junction-case	$R_{\theta JC}$	1.5		

## 7. Electrical characteristics

(T<sub>J</sub>=25°C, unless otherwise notes)

Parameter	Symbol	Conditions	Min	Typ	Max	Units
Off characteristics						
Drain-source breakdown voltage	BV <sub>DSS</sub>	V <sub>GS</sub> =0V, I <sub>D</sub> =250μA	200	-	-	V
Drain-to-source Leakage Current	I <sub>DSS</sub>	V <sub>DS</sub> =200V, V <sub>GS</sub> =0V	-	-	1	μA
		V <sub>DS</sub> =160V, V <sub>GS</sub> =0V T <sub>C</sub> =125°C,	-	-	10	μA
Gate-body leakage current	I <sub>GSS</sub>	V <sub>GS</sub> =20V, V <sub>DS</sub> =0V	-	-	+100	nA
		V <sub>GS</sub> =-20V, V <sub>DS</sub> =0V	-	-	-100	nA
On characteristics						
Static drain-source on-resistance	R <sub>DS(on)</sub>	V <sub>GS</sub> =10V, I <sub>D</sub> =4.5A	-	250	300	mΩ
		V <sub>GS</sub> =4.5V, I <sub>D</sub> =4.5A	-	270	320	mΩ
Gate threshold voltage	V <sub>GS(th)</sub>	V <sub>DS</sub> =V <sub>GS</sub> , I <sub>D</sub> =250μA	1.0	-	3.0	V
Forward Transconductance	g <sub>fs</sub>	V <sub>DS</sub> =20V, I <sub>D</sub> =9A	-	9.0	-	S
Dynamic characteristics						
Input capacitance	C <sub>iss</sub>	V <sub>DS</sub> =25V, V <sub>GS</sub> =0V, f=1MHz	-	418	-	pF
Output capacitance	C <sub>oss</sub>		-	94	-	pF
Reverse transfer capacitance	C <sub>rss</sub>		-	55	-	pF
Total gate charge						
Turn-on delay time	t <sub>d(on)</sub>	V <sub>DD</sub> =100V, I <sub>D</sub> =9.0A, V <sub>GS</sub> =10V, R <sub>G</sub> =12Ω	-	7.0	-	ns
Rise time	t <sub>r</sub>		-	6.0	-	ns
Turn-off delay time	t <sub>d(off)</sub>		-	20	-	ns
Fall time	t <sub>f</sub>		-	6.0	-	ns
Total gate charge	Q <sub>g</sub>	V <sub>DD</sub> =100V, I <sub>D</sub> =9.0A, V <sub>GS</sub> =0 to 10V	-	28	-	nC
Gate-source charge	Q <sub>gs</sub>		-	12	-	nC
Gate-drain charge	Q <sub>gd</sub>		-	2.0	-	nC
Drain-source diode characteristics						
Drain-source diode forward voltage	V <sub>SD</sub>	V <sub>GS</sub> =0V, I <sub>S</sub> =9.0A	-	-	1.5	V
Continuous drain-source current <sup>[2]</sup>	I <sub>SD</sub>	Integral pn-diode In MOSFET	-	-	9	A
Pulsed drain-source current <sup>[2]</sup>	I <sub>SM</sub>		-	-	36	A
Reverse recovery time	t <sub>rr</sub>	V <sub>GS</sub> =0V, I <sub>F</sub> =9.0A	-	238	-	ns
Reverse recovery charge	Q <sub>rr</sub>	dI <sub>F</sub> /dt=100A/μs	-	1.0	-	μC

Note: [1] T<sub>J</sub>=+25 °C to +150 °C  
[2] Pulse width≤380μs; duty cycle≤2%.

8. Typical Characteristics

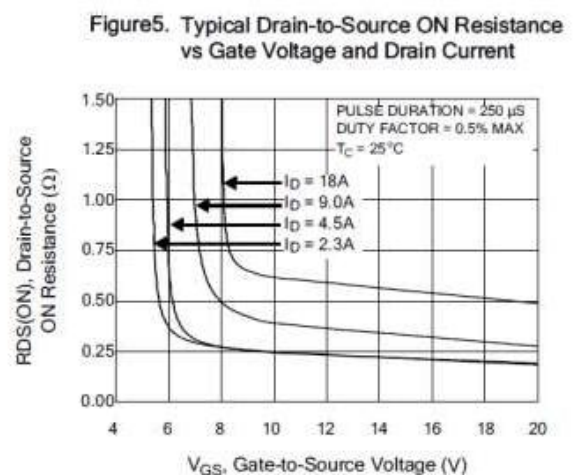
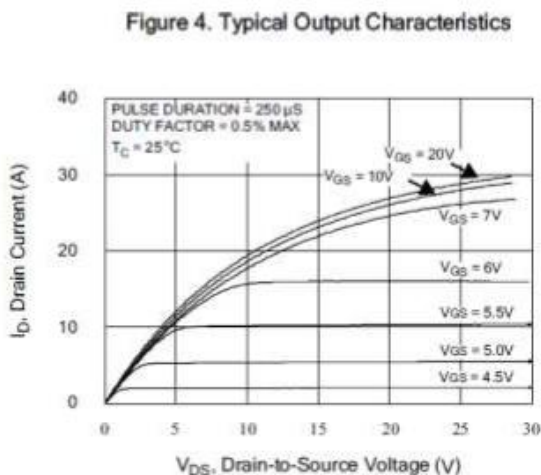
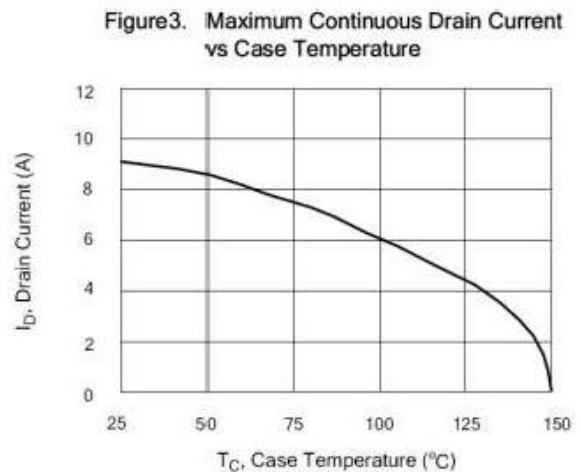
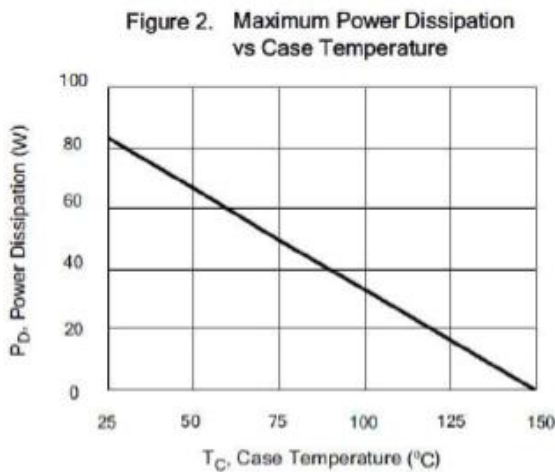
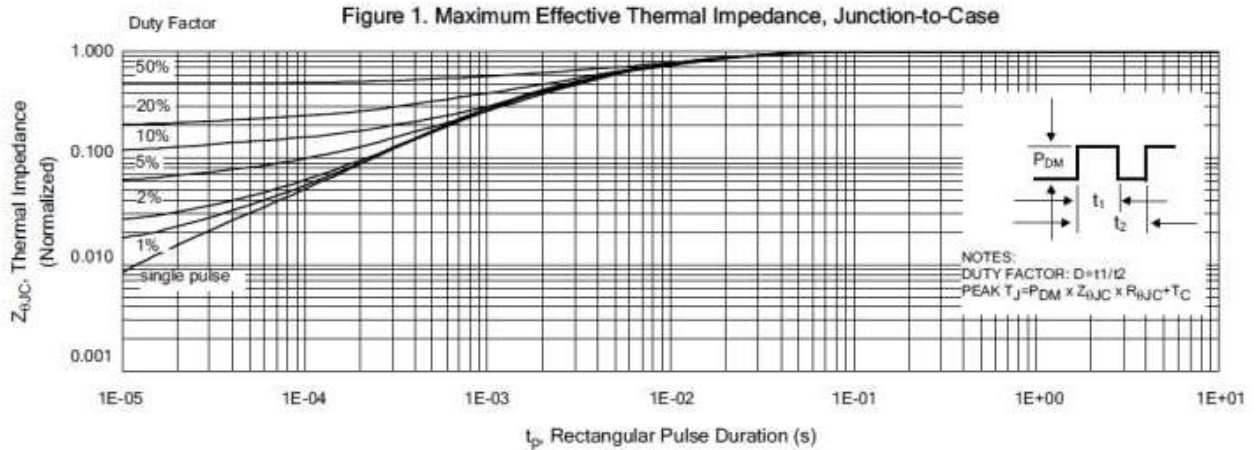

**Figure 6. Maximum Peak Current Capability**

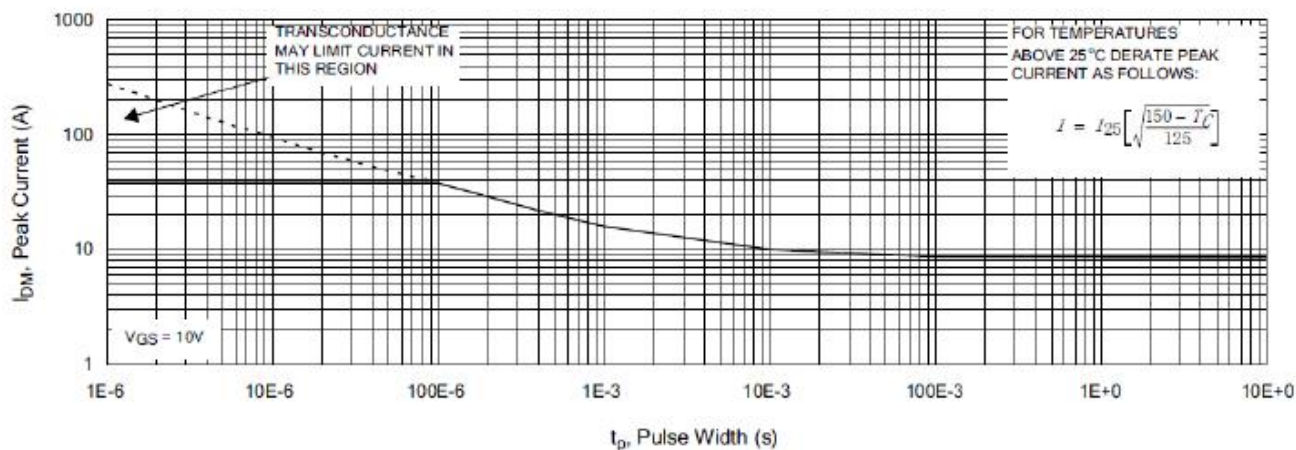

**Figure 7. Typical Transfer Characteristics**

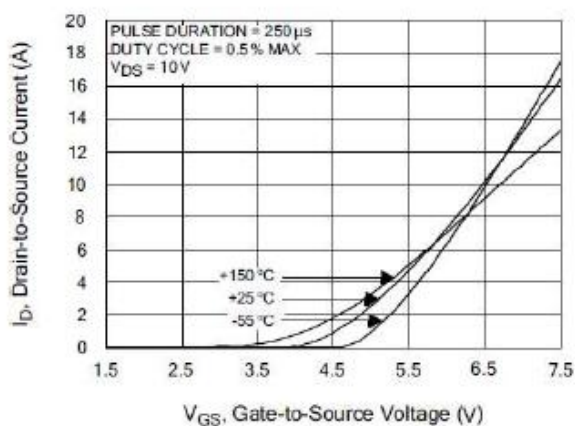

**Figure 8. Unclamped Inductive Switching Capability**

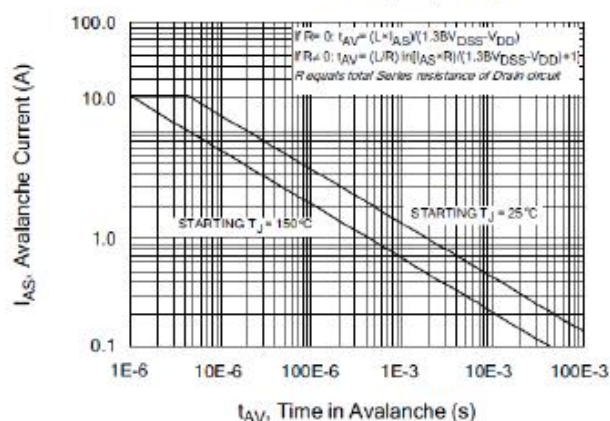

**Figure 9. Typical Drain-to-Source ON Resistance vs Drain Current**

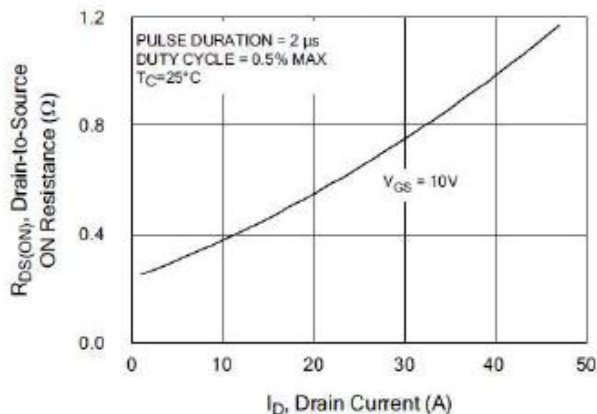

**Figure 10. Typical Drain-to-Source ON Resistance vs Junction Temperature**

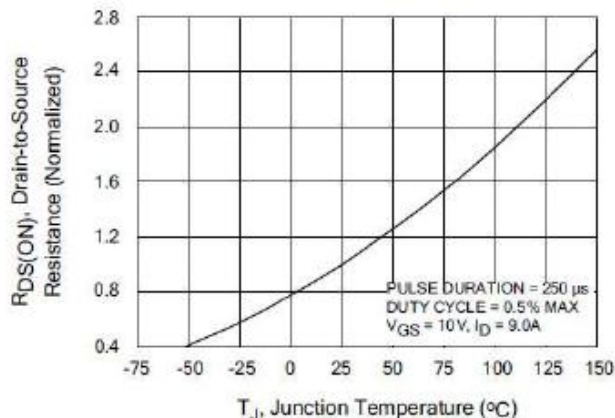



Figure 11. Typical Breakdown Voltage vs Junction Temperature

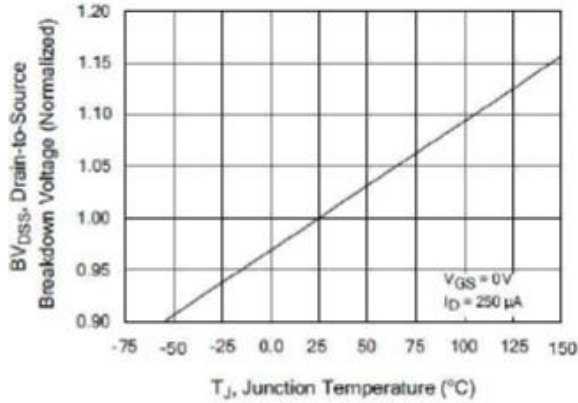

Figure 12. Typical Threshold Voltage vs Junction Temperature

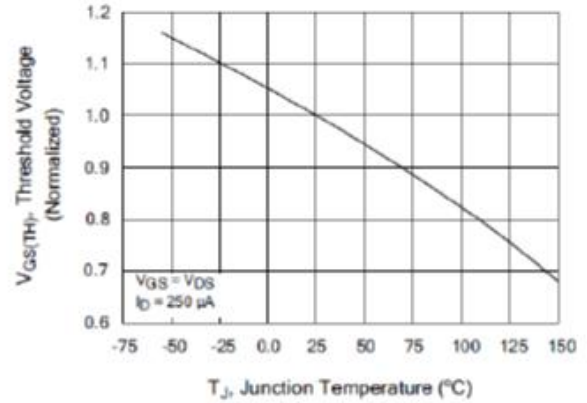

Figure 13. Maximum Forward Bias Safe Operating Area

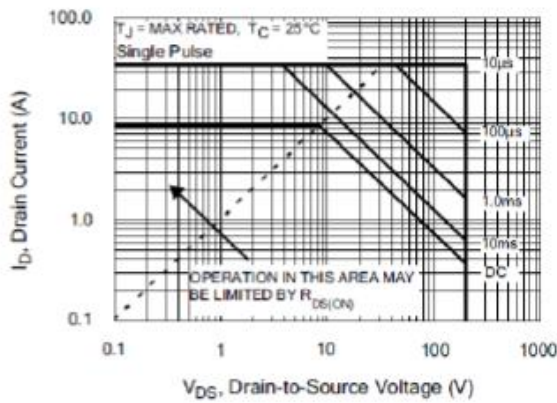

Figure 14. Typical Capacitance vs Drain-to-Source Voltage

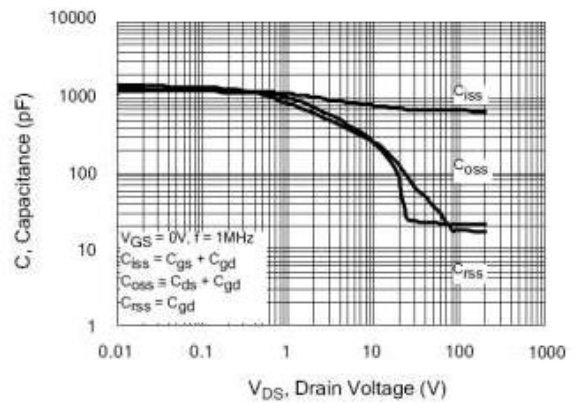

Figure 15. Typical Gate Charge

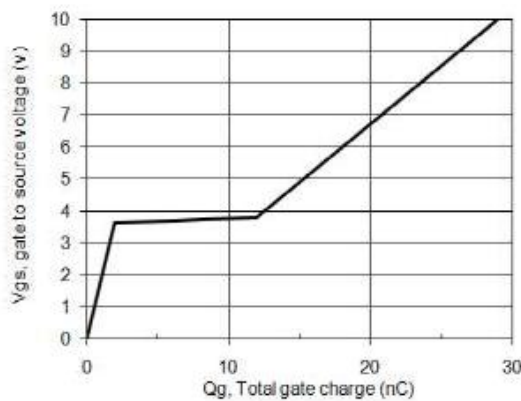
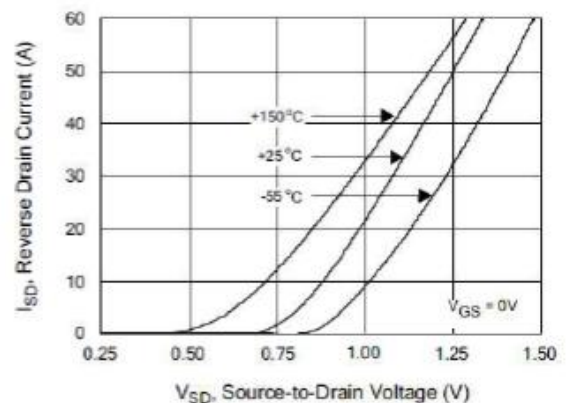

Figure 16. Typical Body Diode Transfer Characteristics



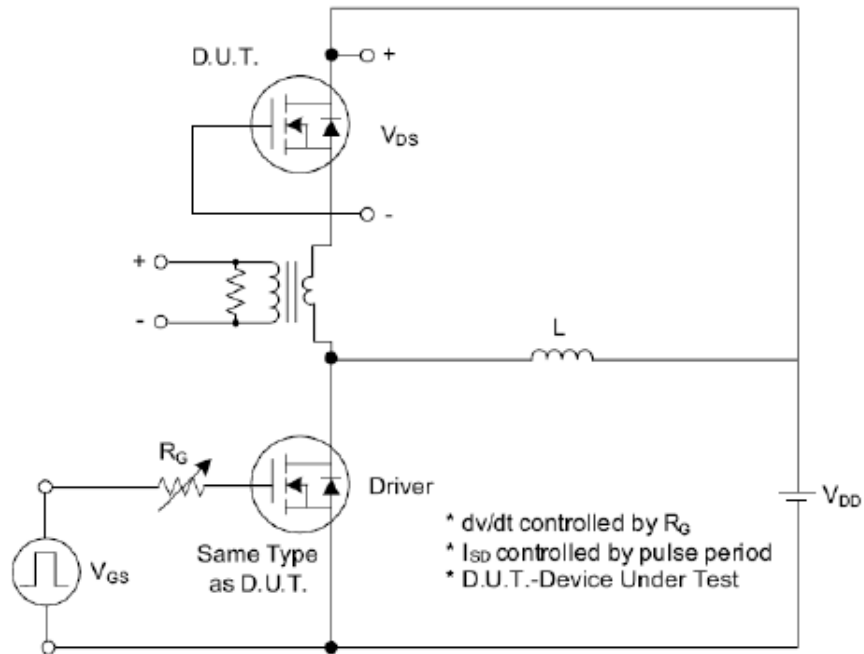

Fig. 1.1 Peak Diode Recovery  $dv/dt$  Test Circuit

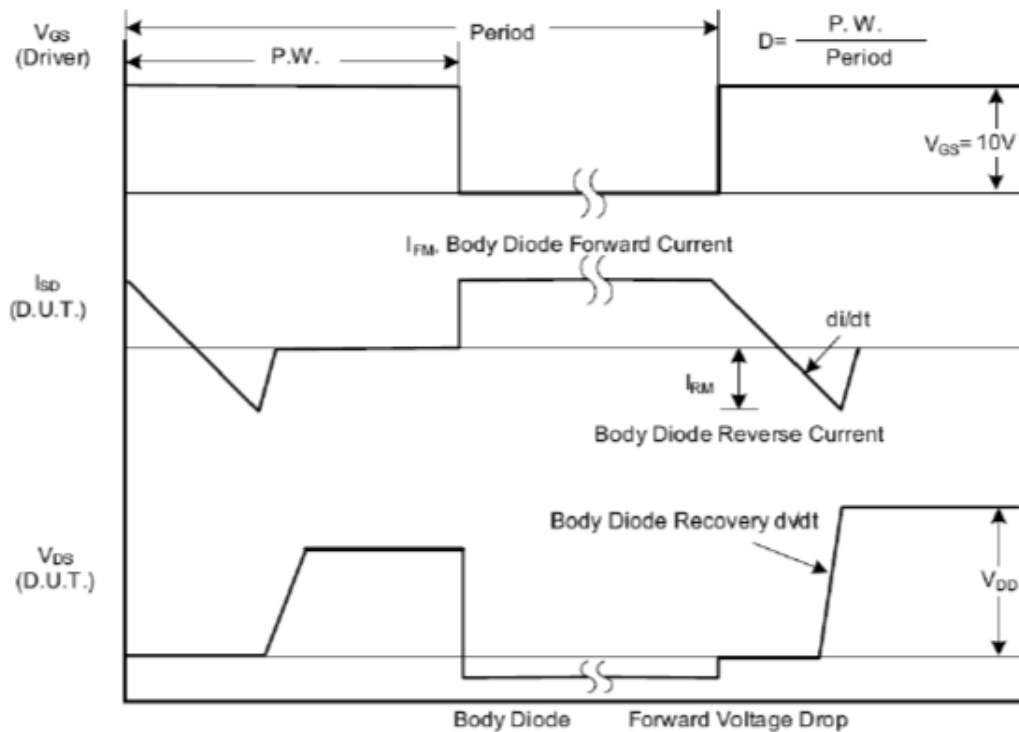

Fig. 1.2 Peak Diode Recovery  $dv/dt$  Waveforms

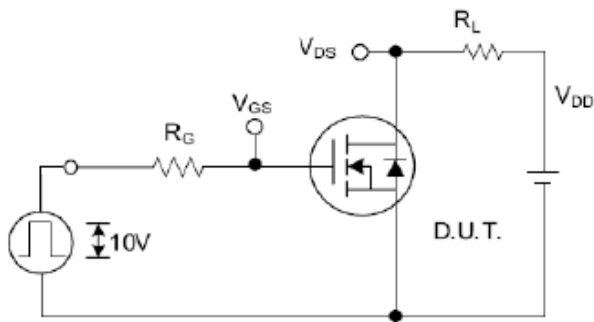

Fig. 2.1 Switching Test Circuit

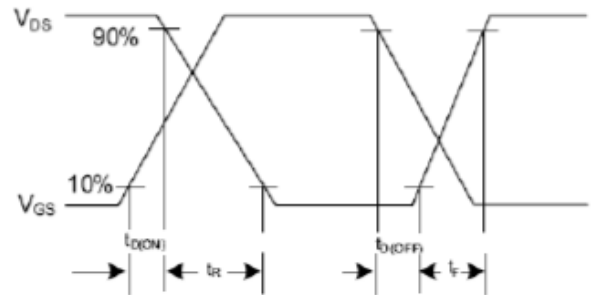

Fig. 2.2 Switching Waveforms

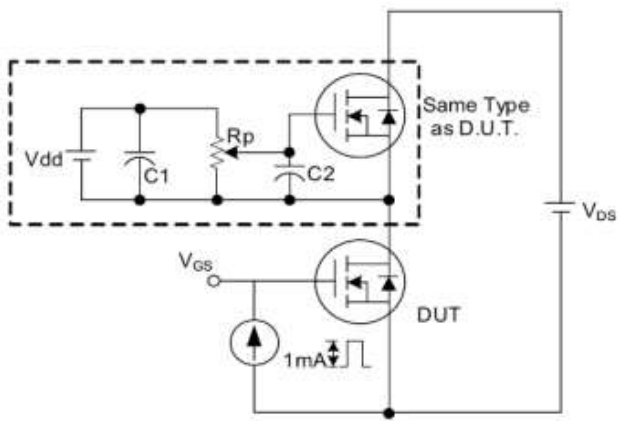

Fig. 3. 1 Gate Charge Test Circuit

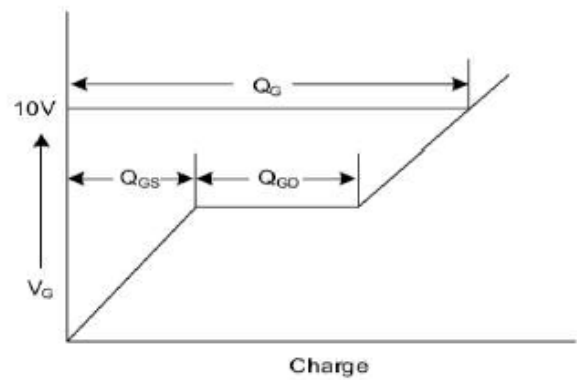

Fig. 3. 2 Gate Charge Waveform

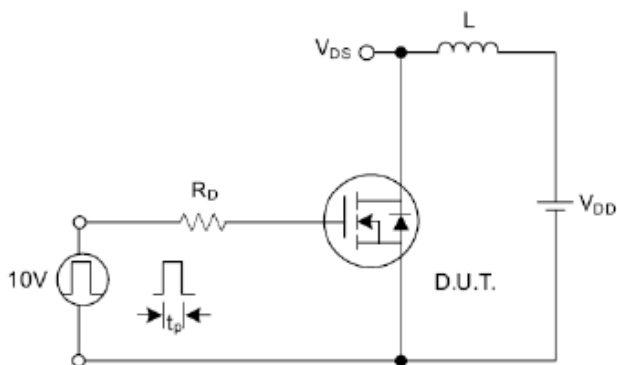

Fig. 4.1 Unclamped Inductive Switching Test Circuit

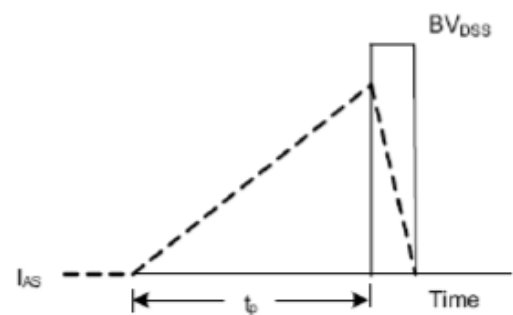

Fig. 4.2 Unclamped Inductive Switching Waveforms