



USB3503

USB 2.0 HSIC High-Speed Hub Controller Optimized for Portable Applications

PRODUCT FEATURES

Data Sheet

Features

- Integrated USB 2.0 Compatible 3-Port Hub.
- HSIC Upstream Port
- Advanced power saving features
 - 1 μ A Typical Standby Current
 - Port goes into power saving state when no devices are connected downstream
 - Port is shutdown when port is disabled.
 - Digital core shut down in Standby Mode
- Supports either Single-TT or Multi-TT configurations for Full-Speed and Low-Speed connections.
- Enhanced configuration options available through serial I2C Slave Port
 - VID/PID/DID
 - String Descriptors
 - Configuration options for Hub.
- Internal Default configuration option when serial I2C host not available.
- MultiTRAK™
 - Dedicated Transaction Translator per port.
- PortMap
 - Configurable port mapping and disable sequencing.
- PortSwap
 - Configurable differential intra-pair signal swapping.
- PHYBoost™
 - Programmable USB transceiver drive strength for recovering signal integrity
- VariSense™
 - Programmable USB receiver sensitivity
- flexPWR® Technology
 - Low current design ideal for battery powered applications
 - Internal supply switching provides low power modes
- External 12, 19.2, 24, 25, 26, 27, 38.4, or 52 MHz clock input
- Internal 3.3V & 1.2V Voltage Regulators for single supply operation.
 - External VBAT and 1.8V dual supply input option
- Internal Short Circuit protection of USB differential signal pins.

- USB Port ESD Protection (**DP/DM**)
 - ± 15 kV (air and contact discharge)
 - IEC 61000-4-2 level 4 ESD protection without external devices
- 25-pin WLCS (1.97mm x 1.97mm Wafer Level Chip Scale) Package - 0.4mm ball pitch
- 32-pin SQFN (5.0 mm x 5.0 mm) Package

Applications

The USB3503 is targeted for applications where more than one USB port is required. As mobile devices add more features and the systems become more complex it is necessary to have more than one USB port to take communicate with the internal and peripheral devices.

- Mobile Phones
- Tablet Computers
- Ultra Mobile PCs
- Digital Still Cameras
- Digital Video Camcorders
- Gaming Consoles
- PDAs
- Portable Media Players
- GPS Personal Navigation Devices
- Media Players/Viewers

USB3503

Order Number(s):

ORDER NUMBER	TEMPERATURE RANGE	PACKAGE TYPE	INFO
USB3503A-1-GL-TR	0C to 70C	25-Ball WLCSP	3000 piece reel
USB3503AI-1-GL-TR	-40C to 85C	25-Ball WLCSP	3000 piece reel
USB3503/ML	0C to 70C	32-Pin SQFN	tray
USB3503-I/ML	-40C to 85C	32-Pin SQFN	tray
USB3503T/ML	0C to 70C	32-Pin SQFN	4000 piece reel
USB3503T-I/ML	-40C to 85C	32-Pin SQFN	4000 piece reel

This product meets the halogen maximum concentration values per IEC61249-2-21

Table of Contents

Chapter 1 General Description	8
1.1 Customer Selectable Features.....	9
1.1.1 Block Diagram.....	10
Chapter 2 Acronyms and Definitions	11
2.1 Acronyms.....	11
2.2 Reference Documents.....	11
Chapter 3 USB3503 Pin Definitions	12
3.1 Pin Configuration.....	12
3.2 Signal Definitions.....	14
3.3 Pin Descriptions.....	15
3.3.1 Pin Definition.....	15
3.3.2 I/O Type Descriptions.....	18
3.3.3 Reference Clock.....	18
3.3.4 Interrupt.....	19
Chapter 4 Modes of Operation	20
4.1 Operational Mode Flowchart.....	20
4.2 Standby Mode.....	22
4.2.1 External Hardware RESET_N.....	22
4.3 Hub Mode.....	22
4.3.1 Hub Initialization Stage (Hub.Init).....	22
4.3.2 Hub Wait RefClk Stage (Hub.WaitRef).....	22
4.3.3 Hub Configuration Stage (Hub.Config).....	22
4.3.4 Hub Connect Stage (Hub.Connect).....	23
4.3.5 Hub Communication Stage (Hub.Com).....	23
4.3.6 Hub Mode Timing Diagram.....	23
Chapter 5 Configuration Options	25
5.1 Hub Configuration Options.....	25
5.1.1 Multi/Single TT.....	25
5.2 Default Serial Interface Register Memory Map.....	25
5.3 Serial Interface Register Definitions.....	27
5.3.1 Register 00h: Vendor ID (LSB) - VIDL.....	27
5.3.2 Register 01h: Vendor ID (MSB) - VIDM.....	27
5.3.3 Register 02h: Product ID (LSB) - PIDL.....	28
5.3.4 Register 03h: Product ID (MSB) - PIDM.....	28
5.3.5 Register 04h: Device ID (LSB) - DIDL.....	28
5.3.6 Register 05h: Device ID (MSB) - DIDM.....	28
5.3.7 Register 06h: CONFIG_BYTE_1 - CFG1.....	29
5.3.8 Register 07h: Configuration Data Byte 2 - CFG2.....	29
5.3.9 Register 08h: Configuration Data Byte 3 - CFG3.....	30
5.3.10 Register 09h: Non-Removable Device - NRD.....	31
5.3.11 Register 0Ah: Port Disable For Self Powered Operation - PDS.....	31
5.3.12 Register 0Bh: Port Disable For Bus Powered Operation - PDB.....	32
5.3.13 Register 0Ch: Max Power For Self Powered Operation - MAXPS.....	32
5.3.14 Register 0Dh: Max Power For Bus Powered Operation - MAXPB.....	32
5.3.15 Register 0Eh: Hub Controller Max Current For Self Powered Operation - HCMCS.....	33
5.3.16 Register 0Fh: Hub Controller Max Current For Bus Powered Operation - HCMCB.....	33

USB3503

5.3.17 Register 10h: Power-On Time - PWRT	33
5.3.18 Register 11h: Language ID High - LANGIDH	33
5.3.19 Register 12h: Language ID Low - LANGIDL	33
5.3.20 Register 13h: Manufacturer String Length - MFRSL	34
5.3.21 Register 14h: Product String Length - PRDSL	34
5.3.22 Register 15h: Serial String Length - SERSL	34
5.3.23 Register 16h-53h: Manufacturer String - MANSTR	34
5.3.24 Register 54h-91h: Product String - PRDSTR	34
5.3.25 Register 92h-CFh: Serial String - SERSTR	35
5.3.26 Register D0: Downstream Battery Charging Enable - BC_EN	35
5.3.27 Register E5h: Port Power Status - PRTPWR	35
5.3.28 Register E6h: Over Current Sense Control - OCS	36
5.3.29 Register E7h: Serial Port Interlock Control - SP_ILOCK	36
5.3.30 Register E8h: Serial Port Interrupt Status - INT_STATUS	37
5.3.31 Register E9h: Serial Port Interrupt Mask - INT_MASK	38
5.3.32 Register EEh: Configure Portable Hub - CFGP	38
5.3.33 Register F4h: Varisense_UP3 - VSNSUP3	39
5.3.34 Register F5h: Varisense_21 - VSNS21	39
5.3.35 Register F6h: Boost_Up3 - BSTUP3	39
5.3.36 Register F8h: Boost_21 - BST21	40
5.3.37 Register FAh: Port Swap - PRTSP	40
5.3.38 Register FBh: Port Remap 12 - PRTR12	41
5.3.39 Register FCh: Port Remap 34 - PRTR34	42
5.3.40 Register FFh: Status/Command - STCD	42

Chapter 6 Serial Slave Interface 44

6.1 Overview	44
6.2 Interconnecting the USB3503 to an I2C Master	44
6.3 I2C Message format	45
6.3.1 Sequential Access Writes	45
6.3.2 Sequential Access Reads	45
6.3.3 I2C Timing	46

Chapter 7 USB Descriptors 48

7.1 USB Bus Reset	48
7.2 Hub Attached as a High-Speed Device (Customer-Configured for Single-TT Support Only)	48
7.2.1 Standard Device Descriptor	48
7.2.2 Configuration Descriptor	49
7.2.3 Interface Descriptor (Single-TT)	50
7.2.4 Endpoint Descriptor (Single-TT)	51
7.3 Hub Attached as a High-Speed Device (Customer-Configured as Multi-TT Capable)	51
7.3.1 Standard Device Descriptor	51
7.3.2 Configuration Descriptor	52
7.3.3 Interface Descriptor (Single-TT)	53
7.3.4 Endpoint Descriptor (Single-TT)	53
7.3.5 Interface Descriptor (Multi-TT)	54
7.3.6 Endpoint Descriptor (Multi-TT)	54
7.4 Class-Specific Hub Descriptor	55
7.5 String Descriptors	58
7.5.1 String Descriptor Zero (specifies languages supported)	58
7.5.2 String Descriptor 1 (Manufacturer String)	58
7.5.3 String Descriptor 2 (Product String)	58
7.5.4 String Descriptor 3 (Serial String)	58

Chapter 8 Battery Charging	60
8.1 Downstream Port Battery Charging Support	60
8.1.1 USB Battery Charging	60
8.1.2 Special Behavior of PRTPWR Register	60
8.1.3 Battery Charging Configuration	61

Chapter 9 Integrated Power Regulators	62
9.1 Overview	62
9.1.1 3.3V Regulator	62
9.1.2 1.2V Regulator	62
9.2 Power Configurations	62
9.2.1 Single Supply Configurations	62
9.2.1.1 VBAT Only	62
9.2.1.2 3.3V Only	62
9.2.2 Double Supply Configurations	62
9.2.2.1 VBAT + 1.8V	62
9.2.2.2 3.3V + 1.8V	63
9.3 Regulator Control Signals	63

Chapter 10 Specifications	64
10.1 Absolute Maximum Ratings	64
10.2 Recommended Operating Conditions	64
10.3 Operating Current	65
10.4 DC Characteristics: Digital I/O Pins	67
10.5 DC Characteristics: Analog I/O Pins	67
10.6 Dynamic Characteristics: Digital I/O Pins	69
10.7 Dynamic Characteristics: Analog I/O Pins	69
10.8 Regulator Output Voltages and Capacitor Requirement	70
10.9 ESD and Latch-Up Performance	70
10.10 ESD Performance	71
10.10.1 Human Body Model (HBM) Performance	71
10.10.2 EN 61000-4-2 Performance	71
10.10.3 Air Discharge	71
10.10.4 Contact Discharge	71
10.11 AC Specifications	71
10.11.1 REFCLK	71
10.11.2 Serial Interface	71
10.11.3 USB 2.0	71
10.11.4 USB 2.0 HSIC	72

Chapter 11 Application Reference	73
11.1 Application Diagram	73

Chapter 12 Package Outlines, Tape & Reel Drawings, Package Marking	76
12.1 25-Ball WLCSP	76
12.2 32-Pin SQFN	81

Chapter 13 Datasheet Revision History	84
--	-----------

USB3503

List of Figures

Figure 1.1	USB3503 Block Diagram	10
Figure 3.1	USB3503 25-Ball WLCSP Package	12
Figure 3.2	USB3503 32-Pin SQFN Package	13
Figure 3.3	INT_N Operation	19
Figure 4.1	Modes of Operation Flowchart	21
Figure 4.2	Timing Diagram for Hub Stages	23
Figure 6.1	I2C Connections	44
Figure 6.2	I2C Sequential Access Write Format	45
Figure 6.3	Sequential Access Read Format	45
Figure 6.4	I2C Timing Diagram	46
Figure 8.1	Battery Charging External Power Supply	60
Figure 11.1	Internal Chip-to-Chip Interface	74
Figure 11.2	Internal Chip-to-Chip Interface with Embedded Host Port	75
Figure 12.1	25-Ball WLCSP, 1.97x1.97mm Body, 0.4mm Pitch Package Drawing	76
Figure 12.2	25-Ball WLCSP Tape and Reel	77
Figure 12.3	25-Ball WLCSP Reel Dimensions	78
Figure 12.4	25-Ball WLCSP Tape Sections	79
Figure 12.5	25-Ball WLCSP Reflow Profile and Critical Parameters for RoHS Compliant (SnAgCu) Solder	79
Figure 12.6	25-Ball WLCSP Package Marking	80
Figure 12.7	32-SQFN Package	81
Figure 12.8	Recommended PCB Land Pattern	82
Figure 12.9	Taping Dimensions and Part Orientation	82
Figure 12.10	Reel Dimensions	83
Figure 12.11	Tape Length and Part Quantity	83

List of Tables

Table 3.1	Pin Descriptions	15
Table 3.2	USB3503 I/O Type Descriptions	18
Table 3.3	USB3503 Primary Reference Clock Frequencies	18
Table 3.4	USB3503 Secondary Reference Clock Frequencies	18
Table 4.1	Controlling Modes of Operation	20
Table 4.2	Timing Parameters for Hub Stages	24
Table 5.1	Transaction Translator Buffer Chart	25
Table 5.2	Serial Interface Registers	25
Table 6.1	I2C Timing Specifications	46
Table 7.1	Device Descriptor	48
Table 7.2	Configuration Descriptor (High-Speed, Single-TT Only)	49
Table 7.3	Interface Descriptor (High-Speed, Single-TT)	50
Table 7.4	Endpoint Descriptor (For Status Change Endpoint, Single-TT)	51
Table 7.5	Device Descriptor (High-Speed)	51
Table 7.6	Configuration Descriptor (High-Speed)	52
Table 7.7	Interface Descriptor (High-Speed, Single-TT)	53
Table 7.8	Endpoint Descriptor (For Status Change Endpoint, Single-TT)	54
Table 7.9	Interface Descriptor (Multi-TT, High-Speed)	54
Table 7.10	EndPoint Descriptor (For Status Change Endpoint, Multi-TT)	54
Table 7.11	Class-Specific Hub Descriptor	55
Table 7.12	String Descriptor Zero	58
Table 7.13	String Descriptor 1, Manufacturer String	58
Table 7.14	String Descriptor 2, Product String	58
Table 7.15	String Descriptor 3, Serial String	58
Table 10.1	Absolute Maximum Ratings	64
Table 10.2	Recommended Operating Conditions	64
Table 10.3	Operating Current (Dual Supply)	65
Table 10.4	Operating Current (Single Supply)	66
Table 10.5	Digital I/O Characteristics	67
Table 10.6	DC Characteristics: Analog I/O Pins (DP/DM)	67
Table 10.7	Dynamic Characteristics: Digital I/O Pins (RESET_N)	69
Table 10.8	Dynamic Characteristics: Analog I/O Pins (DP/DM)	69
Table 10.9	Regulator Output Voltages and Capacitor Requirement	70
Table 10.10	ESD and Latch-up Performance	70
Table 11.1	Component Values in Application Diagrams	73
Table 11.2	Capacitance Values at VBUS of USB Connector	73
Table 12.1	32-SQFN Dimensions	81
Table 13.1	Revision History	84

USB3503

Chapter 1 General Description

The USB3503 is a low-power, USB 2.0 hub controller with HSIC upstream connectivity and three USB 2.0 downstream ports. The USB3503 operates as a hi-speed hub and supports low-speed, full-speed, and hi-speed downstream devices on all of the enabled downstream ports.

The USB3503 has been specifically optimized for mobile embedded applications. The pin-count has been reduced by optimizing the USB3503 for mobile battery-powered embedded systems where power consumption, small package size, and minimal BOM are critical design requirements. Standby mode power has been minimized. Instead of a dedicated crystal, reference clock inputs are aligned to mobile applications. Flexible integrated power regulators ease integration into battery powered devices. All required resistors on the USB ports are integrated into the hub. This includes all series termination resistors on D+ and D- pins and all required pull-down resistors on D+ and D- pins.

The USB3503 includes programmable features such as:

MultiTRAK™ Technology, which utilizes a dedicated Transaction Translator (TT) per port to maintain consistent full-speed data throughput regardless of the number of active downstream connections. MultiTRAK™ outperforms conventional USB 2.0 hubs with a single TT in USB full-speed data transfers.

PortMap, which provides flexible port mapping and disable sequences. The downstream ports of a USB3503 hub can be reordered or disabled in any sequence to support multiple platform designs with minimum effort. For any port that is disabled, the USB3503 hub controllers automatically reorder the remaining ports to match the USB host controller's port numbering scheme.

PortSwap, which adds per-port programmability to USB differential-pair pin locations. PortSwap allows direct alignment of USB signals (D+/D-) to connectors to avoid uneven trace length or crossing of the USB differential signals on the PCB.

PHYBoost, which provides programmable levels of Hi-Speed USB signal drive strength in the downstream port transceivers. PHYBoost attempts to restore USB signal integrity in a compromised system environment. The graphic on the right shows an example of Hi-Speed USB eye diagrams before and after PHYBoost signal integrity restoration.

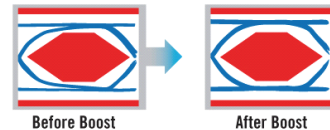

VariSense, which controls the USB receiver sensitivity enabling programmable levels of USB signal receive sensitivity. This capability allows operation in a sub-optimal system environment, such as when a captive USB cable is used.

1.1 Customer Selectable Features

A default configuration is available in the USB3503 following a reset. This configuration may be sufficient for most applications. The USB3503 hub may also be configured by an external microcontroller. When using the microcontroller interface, the hub appears as an I²C slave device.

The USB3503 hub supports customer selectable features including:

- Optional customer configuration via I²C.
- Supports compound devices on a port-by-port basis.
- Customizable vendor ID, product ID, and device ID.
- Configurable downstream port power-on time reported to the host.
- Supports indication of the maximum current that the hub consumes from the USB upstream port.
- Supports Indication of the maximum current required for the hub controller.
- Configurable as a either a Self-Powered or Bus-Powered Hub
- Supports custom string descriptors (up to 30 characters):
 - Product string
 - Manufacturer string
 - Serial number string
- When available, I²C configurable options for default configuration may include:
 - Downstream ports as non-removable ports
 - Downstream ports as disabled ports
 - USB signal drive strength
 - USB receiver sensitivity
 - USB differential pair pin location

USB3503

1.1.1 Block Diagram

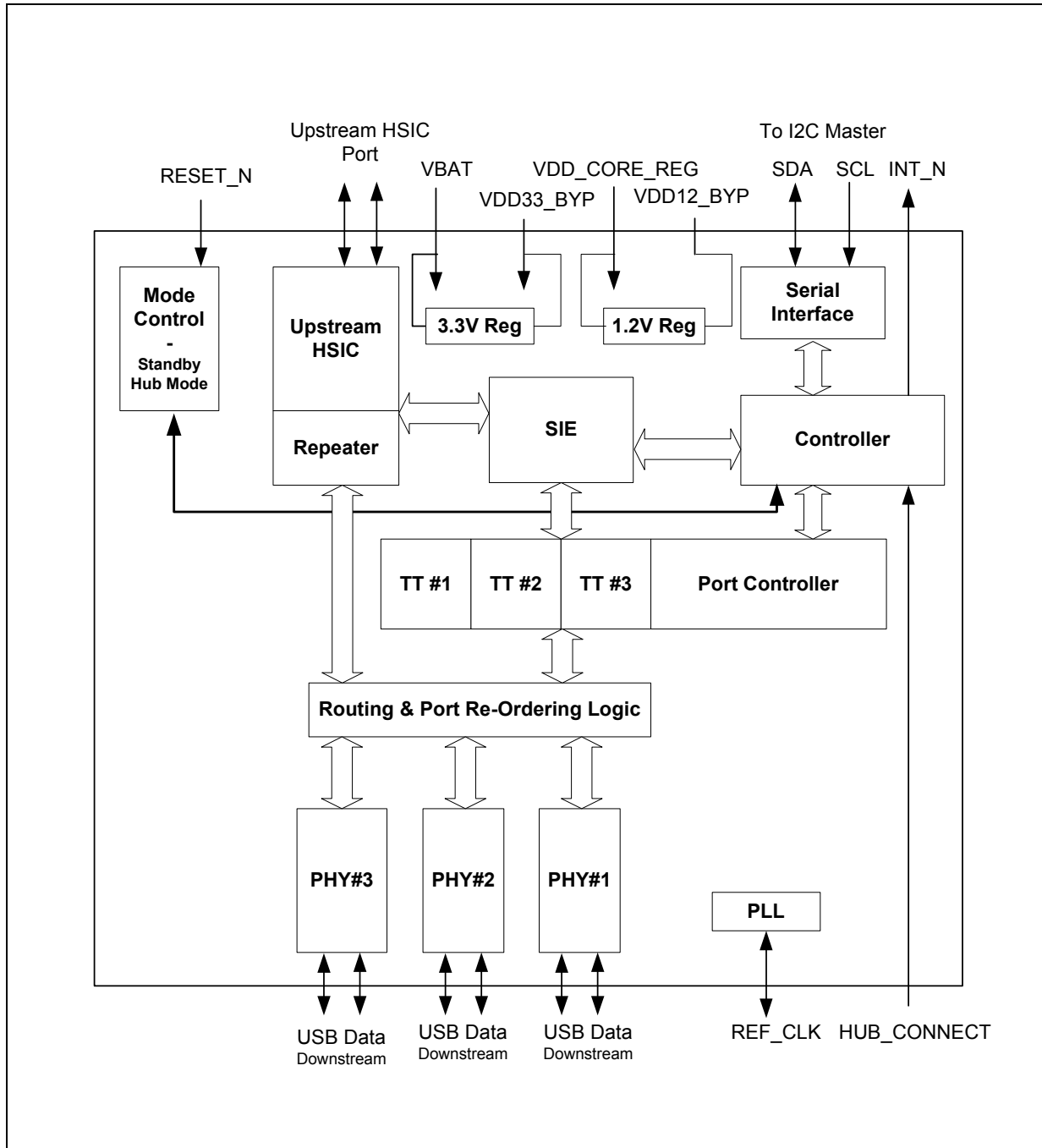

Figure 1.1 USB3503 Block Diagram

Chapter 2 Acronyms and Definitions

2.1 Acronyms

EP: Endpoint

FS: Full-Speed

HS: Hi-Speed

I²C[®]: Inter-Integrated Circuit¹

LS: Low-Speed

HSIC: High-Speed Inter-Chip

2.2 Reference Documents

1. USB Engineering Change Notice dated December 29th, 2004, *UNICODE UTF-16LE For String Descriptors*.
2. *Universal Serial Bus Specification*, Revision 2.0, Dated April 27th, 2000.
3. *Battery Charging Specification*, Revision 1.1, Release Candidate 10, Dated Sept. 22, 2008
4. *High-Speed Inter-Chip USB Electrical Specification*, Version 1.0, Dated Sept. 23, 2007

1. I²C is a registered trademark of Philips Corporation.

USB3503

Chapter 3 USB3503 Pin Definitions

3.1 Pin Configuration

Figure 3.1 details the 25-ball WLCSP package. Figure 3.2 details the 32-pin SQFN package pin configuration. Signal definitions are provided in Section 3.2.

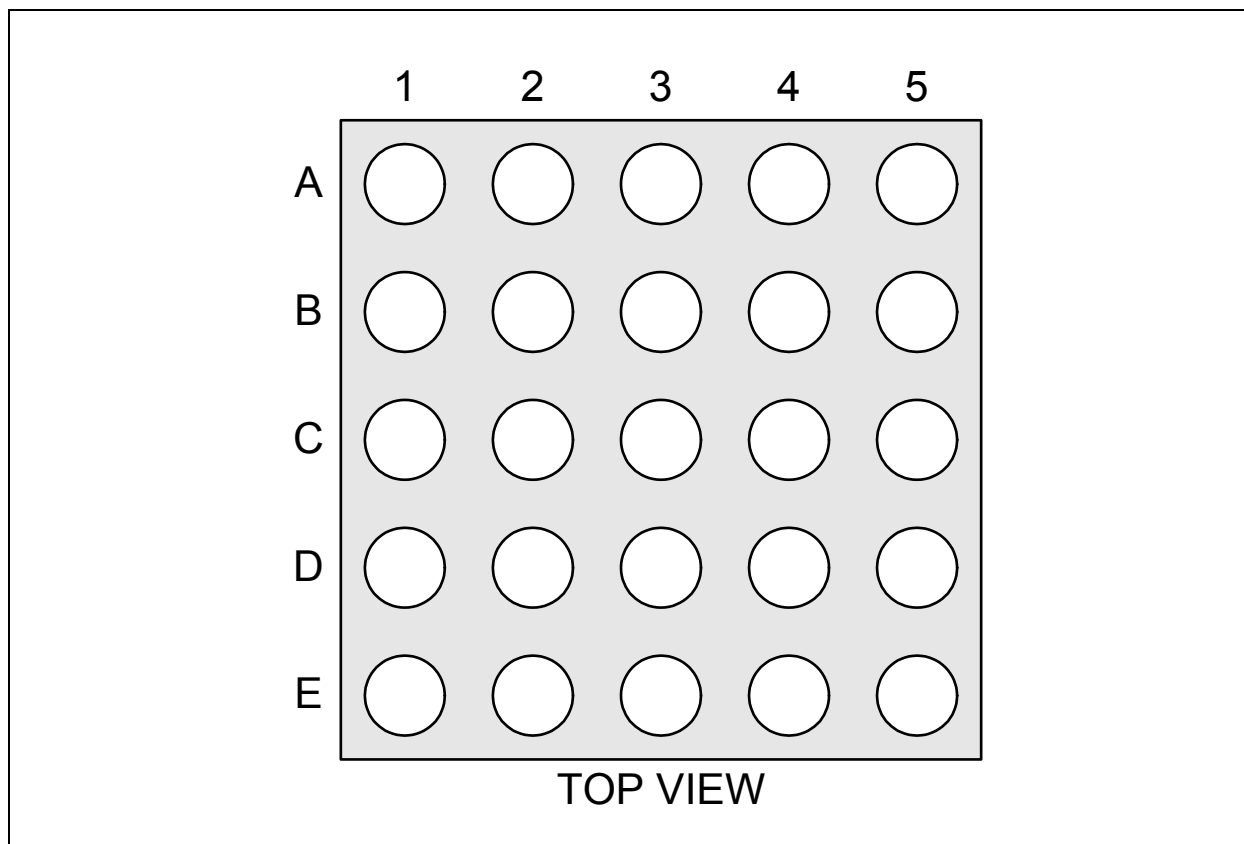

Figure 3.1 USB3503 25-Ball WLCSP Package

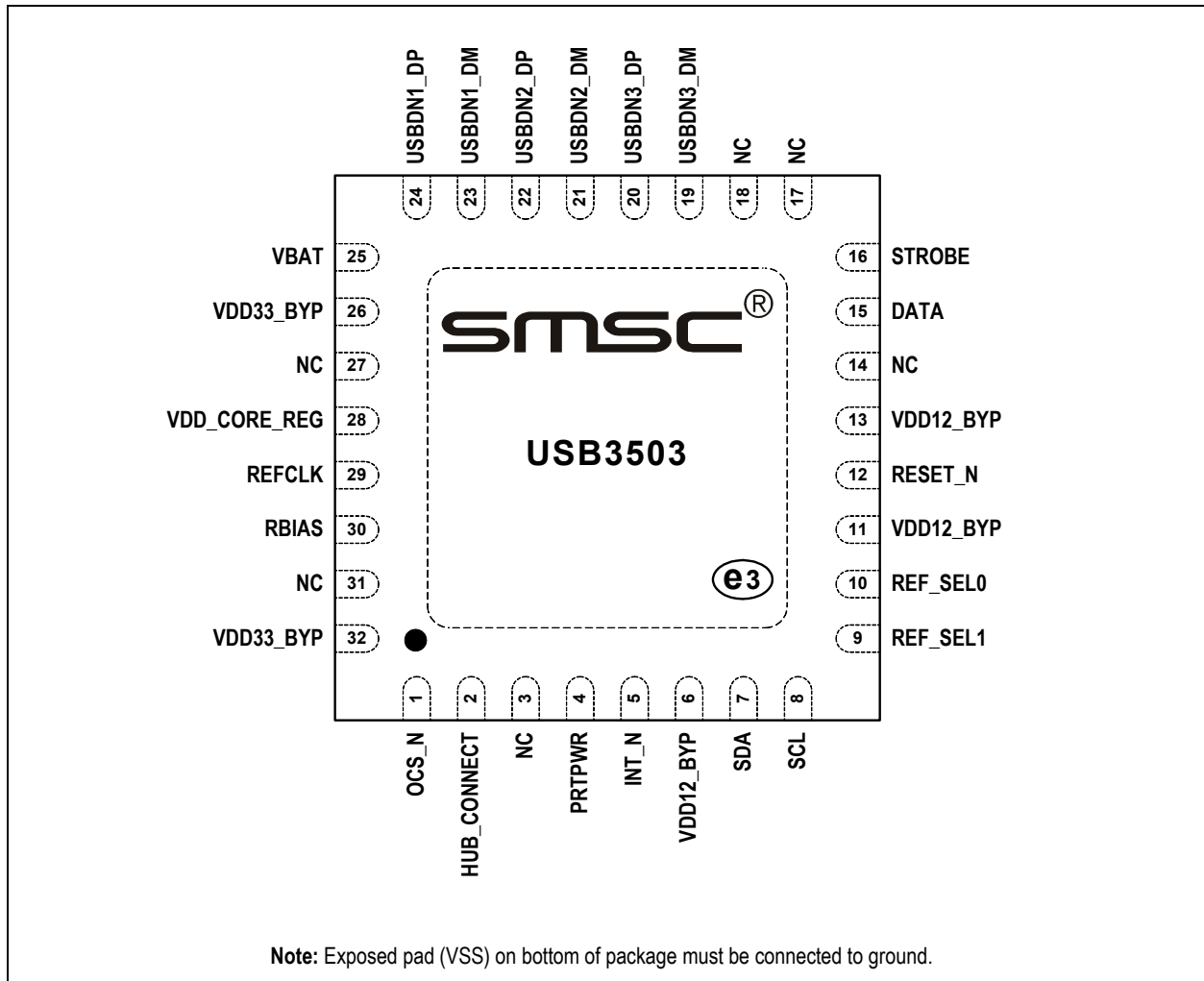

Figure 3.2 USB3503 32-Pin SQFN Package

USB3503

3.2 Signal Definitions

WLCSP BALL	SQFN PIN	NAME	DESCRIPTION
E2	15	DATA	Upstream HSIC DATA pin of the USB Interface
E1	16	STROBE	Upstream HSIC STROBE pin of the USB Interface
A5	32	VDD33_BYP	3.3 V Regulator Bypass
C4	4	PRTPWR	Port Power Control Output
B4	1	OCS_N	Over Current Sense Input
A1	24	USBDN1_DP	USB downstream Port 1 D+ data pin
B1	23	USBDN1_DM	USB downstream Port 1 D- data pin
C2	22	USBDN2_DP	USB downstream Port 2 D+ data pin
D2	21	USBDN2_DM	USB downstream Port 2 D- data pin
C1	20	USBDN3_DP	USB downstream Port 3 D+ data pin
D1	19	USBDN3_DM	USB downstream Port 3 D- data pin
E5	8	SCL	I ² C clock input
D5	7	SDA	I ² C bi-directional data pin
E3	12	RESET_N	Active low reset signal
B5	2	HUB_CONNECT	Hub Connect
C5	5	INT_N	Active low interrupt signal
D4	9	REF_SEL1	Reference Clock Select 1 input
E4	10	REF_SEL0	Reference Clock Select 0 input
B3	29	REFCLK	Reference Clock input
A4	30	RBIAS	Bias Resistor pin
D3	6,11,13	VDD12_BYP	1.2 V Regulator
A2	26	VDD33_BYP	3.3 V Regulator
B2	25	VBAT	Voltage input from the battery supply
A3	28	VDD_CORE_REG	Power supply input to 1.2V regulator for digital logic core
C3	e-pad	VSS	Ground
-	3,14,17, 18,27,31	NC	No connect

3.3 Pin Descriptions

This section provides a detailed description of each signal. The signals are arranged in functional groups according to their associated interface.

The terms assertion and negation are used. This is done to avoid confusion when working with a mixture of “active low” and “active high” signal. The term “assert”, or “assertion” indicates that a signal is active, independent of whether that level is represented by a high or low voltage. The term “negate”, or “negation” indicates that a signal is inactive.

3.3.1 Pin Definition

Table 3.1 Pin Descriptions

NAME	SYMBOL	TYPE	DESCRIPTION
UPSTREAM HIGH SPEED INTER-CHIP INTERFACE			
HSIC Clock/Strobe	STROBE	I/O	HSIC Upstream Hub Strobe pin
HSIC Data	DATA	I/O	HSIC Upstream Hub Data pin
High-Speed USB Data & Port Disable Strap Option	USBDN_DP[2:1] & USBDN_DM[2:1]	A-I/O	These pins connect to the downstream USB peripheral devices attached to the hub's ports
			Downstream Port Disable Strap option: This pin will be sampled at RESET_N negation to determine if the port is disabled. Both USB data pins for the corresponding port must be tied to VDD33_BYP to disable the associated downstream port.
HS USB Data	USBDN_DP[3] & USBDN_DM[3]	A-I/O	These pins connect to the downstream USB peripheral devices attached to the hub's ports.
			There is no downstream Port Disable Strap option on these ports.
SERIAL PORT INTERFACE			
Serial Data	SDA	I/OD	I ² C Serial Data
Serial Clock	SCL	I	Serial Clock (SCL)

USB3503

Table 3.1 Pin Descriptions (continued)

NAME	SYMBOL	TYPE	DESCRIPTION
Interrupt	INT_N	OD	<p>Interrupt The function of this pin is determined by the setting in the CFGP.INTSUSP configuration register.</p> <p>When CFGP.INTSUSP = 0 (General Interrupt) A transition from high to low identifies when one of the interrupt enabled status registers has been updated. SOC must update the Serial Port Interrupt Status Register to reset the interrupt pin high.</p> <p>When CFGP.INTSUSP = 1 (Suspend Interrupt) Indicates USB state of the hub. 'Asserted' low = Unconfigured or configured and in USB Suspend 'Negated' high = Hub is configured, and is active (i.e., not in suspend)</p> <p>If unused, this pin must be tied to VDD33_BYP.</p>
Over Current Sense	OCS_N	I	<p>Over Current Sense - Input from external current monitor indicating an over-current condition on port 3 or on ganged supply.</p> <p>Negated High = No over current fault detected Asserted Low = Over Current Fault Reported</p>
Port Power	P RTPWR	OD	<p>Port Power Control- Enables power to USB peripheral devices downstream on port 3 or on ganged supply.</p> <p>Asserted High = External Device should provide power for port(s). Negated Low = External Device should disable power to port(s).</p>
MISC			
Reference Clock Input	REFCLK	I	Reference clock input.
Reference Clock Select	REF_SEL[1:0]	I	<p>The reference select input must be set to correspond to the frequency applied to the REFCLK input. The customer should tie these pins to ground or VDD33_BYP. This input is latched during HUB.Init stage.</p> <p>Selects input reference clock frequency per Table 3.3.</p>
RESET Input	RESET_N	I	This active low signal is used by the system to reset the chip and hold the chip in low power STANDBY MODE.

Table 3.1 Pin Descriptions (continued)

NAME	SYMBOL	TYPE	DESCRIPTION
USB Transceiver Bias	RBIAS	A-I/O	A 12.0k Ω (+/- 1%) resistor is attached from ground to this pin to set the transceiver's internal bias settings.
Hub Connect	HUB_CONNECT	I	<p>Hub will transition to the Hub Communication Stage when this pin is asserted high. It can be used in three different ways:</p> <p>Tied to Ground - Hub will not transition to the Hub Communication Stage until connect_n bit of the SP_ILOCK register is negated.</p> <p>Tied to VDD33_BYP - Hub will automatically transition to the Hub Communication Stage regardless of the setting of the connect_n bit and without pausing for the SOC to reference status registers.</p> <p>Transition from low to high - Hub will transition to the Hub Communication Stage after this pin transitions from low to high. HUB_CONNECT should never be driven high when USB3503 is in Standby Mode.</p>
POWER			
1.2V VDD Power	VDD12_BYP	Power	1.2 V Regulator. A 1.0 μ F (<1 Ω ESR) capacitor to ground is required for regulator stability. The capacitor should be placed as close as possible to the USB3503.
3.3V VDD Power	VDD33_BYP	Power	3.3V Regulator. A 4.7 μ F (<1 Ω ESR) capacitor to ground is required for regulator stability. The capacitor should be placed as close as possible to the USB3503.
Core Power Supply Input	VDD_CORE_REG	Power	<p>Power supply to 1.2V regulator.</p> <p>This power pin should be connected to VDD33_BYP for single supply applications.</p> <p>Refer to Chapter 9 for power supply configuration options.</p>
Battery Power Supply Input	VBAT	Power	<p>Battery power supply.</p> <p>Refer to Chapter 9 for power supply configuration options.</p>
VSS	VSS	Ground	Ground

USB3503

3.3.2 I/O Type Descriptions

Table 3.2 USB3503 I/O Type Descriptions

I/O TYPE	DESCRIPTION
I	Digital Input.
OD	Digital Output. Open Drain.
I/O	Digital Input or Output.
A-I/O	Analog Input or Output.
Power	DC input or Output.
Ground	Ground.

3.3.3 Reference Clock

The REFCLK input is can be driven with a square wave from 0 V to VDD33_BYP. The USB3503 only uses the positive edge of the clock. The duty cycle is not critical.

The USB3503 is tolerant to jitter on the reference clock. The REFCLK jitter should be limited to a peak to peak jitter of less than 1 ns over a 10 μ s time interval. If this level of jitter is exceeded the USB3503 high speed eye diagram may be degraded.

To select the REFCLK input frequency, the REF_SEL pins must be set according to [Table 3.3](#) and [Table 3.4](#). To select the primary REFCLK frequencies defined in [Table 3.3](#), INT_N must be sampled high during the Hub.Init stage. If the INT_N pin is not used, the INT_N pin should be tied to VDD33_BYP. To select the secondary REFCLK frequencies defined in [Table 3.4](#), INT_N must be sampled low during the Hub.Init stage. If the INT_N pin is not used, the INT_N pin should be tied to ground. Since the INT_N pin is open-drain during normal function, selecting the secondary REFCLK frequencies requires that the INT_N pin be driven low from an external source during Hub.Init and then, after startup, that external source must turn into an input to receive the INT_N signal.

Table 3.3 USB3503 Primary Reference Clock Frequencies

REF_SEL[1:0]	FREQUENCY (MHz)
'00'	38.4
'01'	26.0
'10'	19.2
'11'	12.0

Table 3.4 USB3503 Secondary Reference Clock Frequencies

REF_SEL[1:0]	FREQUENCY (MHz)
'00'	24.0
'01'	27.0
'10'	25.0
'11'	50.0

3.3.4 Interrupt

The general interrupt pin (INT_N) is intended to communicate a condition change within the hub. The conditions that may cause an interrupt are captured within a register mapped to the serial port (Register E8h: Serial Port Interrupt Status - INT_STATUS). The conditions that cause the interrupt to assert can be controlled through use of an interrupt mask register (Register E9h: Serial Port Interrupt Mask - INT_MASK).

The general interrupt and all interrupt conditions are functionally latched and event driven. Once the interrupt or any of the conditions have asserted, the status bit will remain asserted until the SOC negates the bit using the serial port. The bits will then remain negated until a new event condition occurs. The latching nature of the register causes the status to remain even if the condition that caused the interrupt ceases to be active. The event driven nature of the register causes the interrupt to only occur when a new event occurs- when a condition is removed and then is applied again.

The function of the interrupt and the associated status and masking registers are illustrated in [Figure 3.3](#). Registers & Register bits shown in the figure are defined in [Table 5.2](#), "Serial Interface Registers," on page 25.

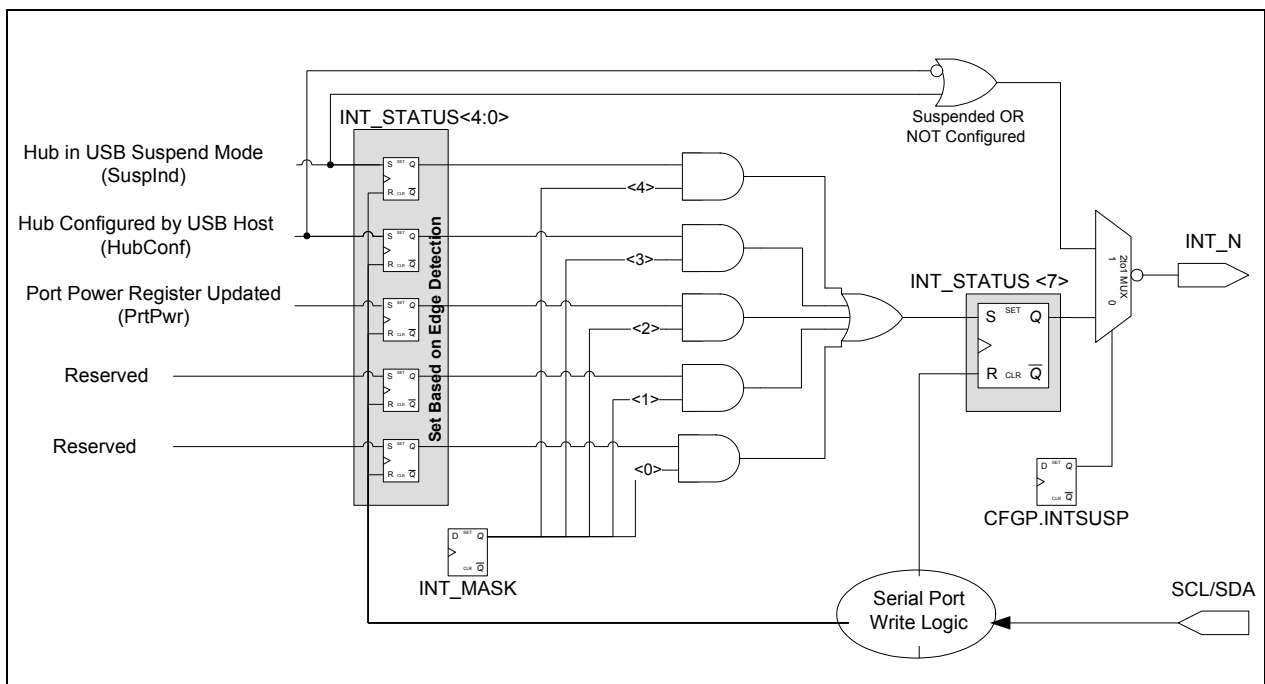

Figure 3.3 INT_N Operation

[Figure 3.3](#) also shows an alternate configuration option (CFGP.INTSUSP) for a suspend interrupt. This option allows the user to change the behavior of the INT_N pin to become a direct level indication of configuration and suspend status.

When selected, the INT_N indicates that the entire hub has entered the USB suspend state.

NOTE: Because INT_N is driven low when active, care must be taken when selecting the external pullup resistor value for this open drain output. A sufficiently large resistor must be selected to insure suspend current requirements can be satisfied for the system.

USB3503

Chapter 4 Modes of Operation

The USB3503 provides two modes of operation - Standby Mode and Hub Mode - which balance power consumption with functionality. The operating mode of the USB3503 is selected by setting values on primary inputs according to the table below.

Table 4.1 Controlling Modes of Operation

RESET_N INPUT	RESULTING MODE	SUMMARY
0	Standby	Lowest Power Mode – no function other than monitoring RESET_N input to move to higher states. All regulators are powered off.
1	Hub	Full Feature Mode - Operates as a configurable USB hub. Power consumption based on how many ports are active, at what speeds they are running and amount of data transferred.

4.1 Operational Mode Flowchart

The flowchart in [Figure 4.1](#) shows the modes of operation. It also shows how the USB3503 traverses through the Hub mode stages (shown in bold.) The flow of control is dictated by control register bits shown in *Italics* as well as other events such as availability of reference clock. Refer to [Section 5.3, "Serial Interface Register Definitions,"](#) on page 27 for the detailed definition of the control register bits. In this specification register bits are referenced using the syntax <Register>.<RegisterBit>. A summary of all registers can be found in [Table 5.2, "Serial Interface Registers,"](#) on page 25.

The remaining sections in this chapter provide more detail on each stage and mode of operation.

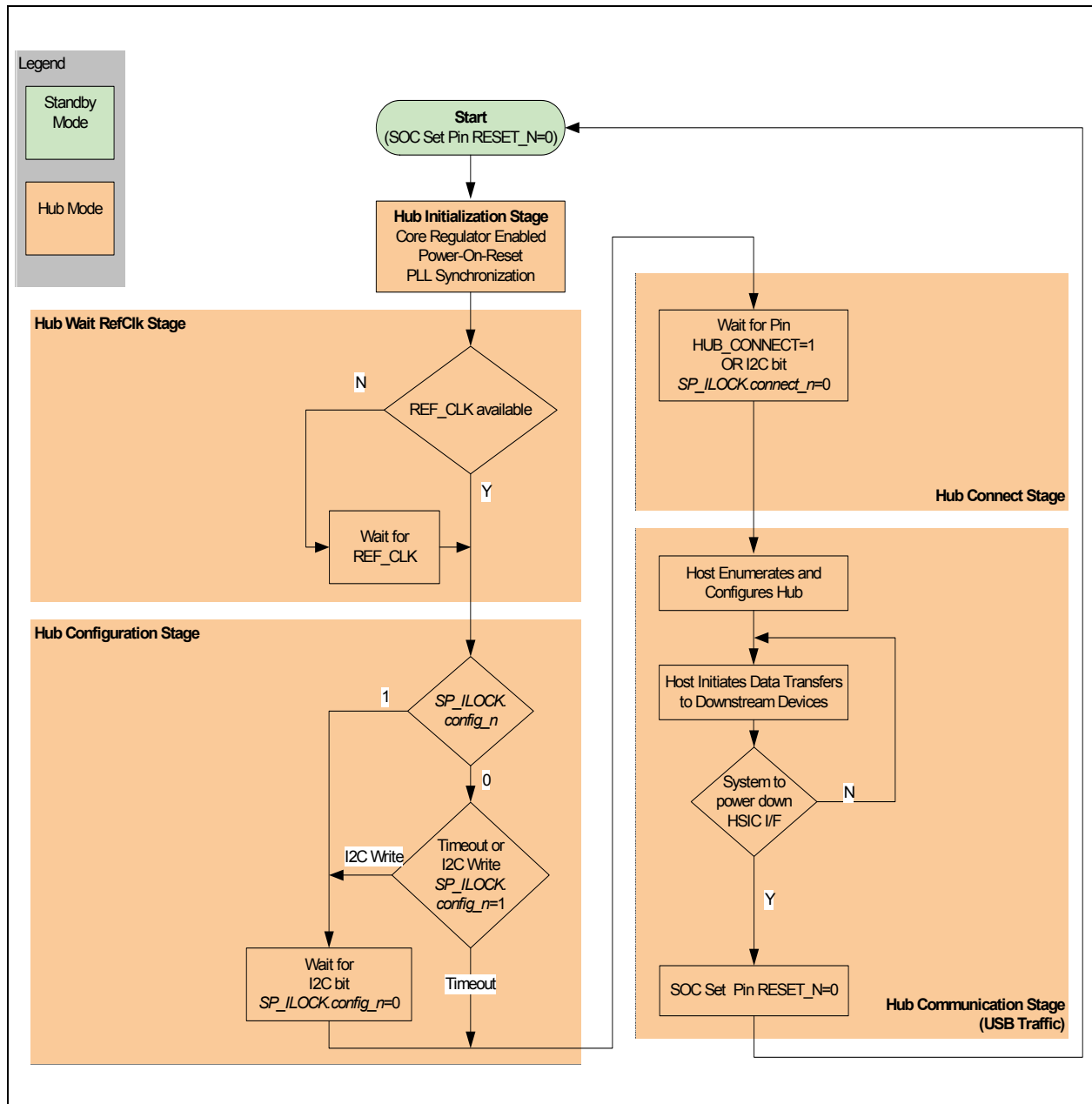

Figure 4.1 Modes of Operation Flowchart

USB3503

4.2 Standby Mode

Standby Mode provides a very low power state for maximum power efficiency when no signaling is required. This is the lowest power state. In Standby Mode all internal regulators are powered off, the PLL is not running, and core logic is powered down in order to reduce power. Because core logic is powered off, no configuration settings are retained in this mode and must be re-initialized after RESET_N is negated high.

4.2.1 External Hardware RESET_N

A valid hardware reset is defined as an assertion of RESET_N low for a minimum of 100us after all power supplies are within operating range. While reset is asserted, the Hub (and its associated external circuitry) enters STANDBY MODE and consumes extremely low current as defined in [Table 10.3](#) and [Table 10.4](#).

Assertion of RESET_N (external pin) causes the following:

- All downstream ports are disabled.
- All transactions immediately terminate; no states are saved.
- All internal registers return to the default state.
- The PLL is halted.

After RESET_N is negated high in the Hub.Init stage, the Hub reads customer-specific data from the ROM.

4.3 Hub Mode

Hub Mode provides functions of configuration and high speed USB hub operation including connection and communication. Upon entering Hub Mode and initializing internal logic, the device passes through several sequential stages based on a fixed time interval.

4.3.1 Hub Initialization Stage (Hub.Init)

The first stage is the initialization stage and occurs when Hub mode is entered based on the conditions in [Table 4.1](#). In this stage the 1.2V regulator is enabled and stabilizes, internal logic is reset, and the PLL locks if a valid REFCLK is supplied. Configuration registers are initialized to their default state and REF_SEL[1:0] input values are latched. The USB3503 will complete initialization and automatically enter the next stage after T_{hubinit} . Because the digital logic within the device is not yet stable, no communication with the device using the serial port is possible. Configuration registers are initialized to their default state.

4.3.2 Hub Wait RefClk Stage (Hub.WaitRef)

During this stage the serial port is not functional.

If the reference clock is provided before entering hub mode, the USB3503 will transition to the Hub Configuration stage without pausing in the Hub Wait RefClk stage. Otherwise, the USB3503 will transition to the Hub configuration stage once a valid reference clock is supplied and the PLL has locked.

4.3.3 Hub Configuration Stage (Hub.Config)

In this stage, the SOC has an opportunity to control the configuration of the USB3503 and modify any of the default configuration settings specified in the integrated ROM. These settings include USB device descriptors, port electrical settings such as PHY BOOST, and control features. The SOC implements the changes using the serial slave port interface to write configuration & control registers.

See [Section 5.3.29, "Register E7h: Serial Port Interlock Control - SP_ILOCK," on page 36](#) for definition of SP_ILOCK register and how it controls progress through hub stages. If the SP_ILOCK.config_n bit

has its default asserted low and the bit is not written by the serial port, then the USB3503 completes configuration without any I2C intervention.

If the SP_ILOCK.config_n bit has its default negated high or the SOC negates the bit high using the serial port during $T_{hubconfig}$, the USB3503 will remain in the Hub Configuration Stage indefinitely. This will allow the SOC to update other configuration and control registers without any remaining time-out restrictions. Once the SP_ILOCK.config_n bit is asserted low by the SOC the device will transition to the next stage.

4.3.4 Hub Connect Stage (Hub.Connect)

Next, the USB3503 enters the Hub Connect Stage. See [Section 5.3.32, "Register EEh: Configure Portable Hub - CFGP," on page 38](#) and [Section 5.3.29, "Register E7h: Serial Port Interlock Control - SP_ILOCK," on page 36](#) for definition of control registers which affect how the device transitions through the hub stages.

By using the appropriate controls, the USB3503 can be set to immediately transition, or instead to remain in the Hub Connect Stage indefinitely until one of the SOC handshake events occur. When set to wait on the handshake, the SOC may read or update any of the serial port registers. Once the SOC finishes accessing registers and is ready for USB communication to start, it can perform one of the selected handshakes which that cause the USB3503 to connect within $T_{hubconnect}$ and transition to the Hub Communication Stage.

4.3.5 Hub Communication Stage (Hub.Com)

Once it exits the Hub Connect Stage, the USB3503 enters Hub Communication Stage. In this stage full USB operation is supported under control of the USB Host on the upstream port. The USB3503 will remain in the Hub Communication Stage until the operating mode is changed by the system asserting RESET_N low.

While in the Hub Communication Stage, communication over the serial port is no longer supported and the resulting behavior of the serial port if accessed is undefined. In order to re-enable the serial port interface, the device must exit Hub Communication Stage. Exiting this stage is only possible by entering Standby mode.

4.3.6 Hub Mode Timing Diagram

The following timing diagram shows the progression through the stages of Hub Mode and the associated timing parameters.

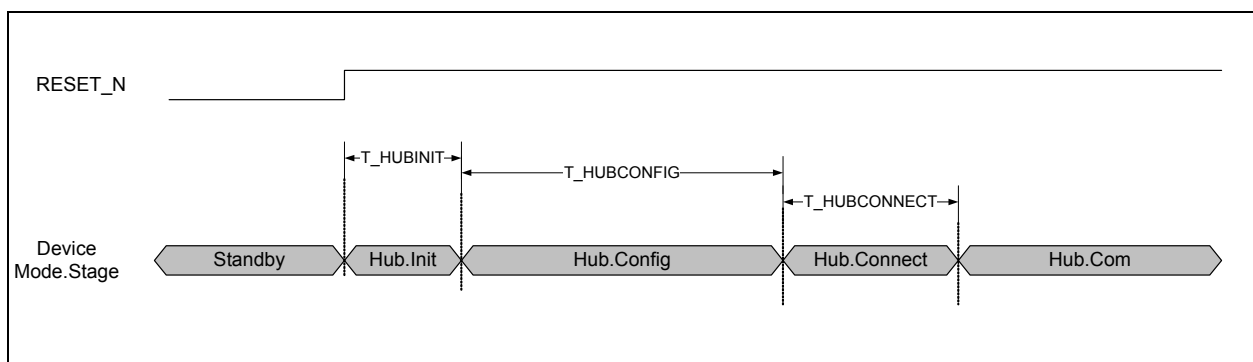

Figure 4.2 Timing Diagram for Hub Stages

The following table lists the timing parameters associated with the stages of the Hub Mode.

USB3503

Table 4.2 Timing Parameters for Hub Stages

CHARACTERISTIC	SYMBOL	MIN	TYP	MAX	UNITS	CONDITIONS
Hub Initialization Time	$T_{HUBINIT}$		3	4	ms	
Hub Configuration Time-out	$T_{HUBCONFIG}$	94	95	96	ms	
Hub Connect Time	$T_{HUBCONNECT}$	0	1	10	us	

Chapter 5 Configuration Options

5.1 Hub Configuration Options

The Hub supports a number of features (some are mutually exclusive), and must be configured in order to correctly function when attached to a USB host controller. There are two principal ways to configure the hub: by writing to configuration registers using the serial slave port, or by internal default settings. Any configuration registers which are not written by the serial slave retain their default settings.

5.1.1 Multi/Single TT

The USB 2.0 Hub is fully specification compliant to the Universal Serial Bus Specification Revision 2.0 April 27,2000 (12/7/2000 and 5/28/2002 Errata). Please reference Chapter 11 (Hub Specification) for general details regarding Hub operation and functionality.

For performance reasons, the Hub provides 1 Transaction Translator (TT) per port (defined as Multi-TT configuration), and each TT has 1512 bytes of periodic buffer space and 272 Bytes of non- periodic buffer space (divided into 4 non-periodic buffers per TT), for a total of 1784 bytes of buffer space for each Transaction Translator.

When configured as a Single-TT Hub (required by USB 2.0 Specification), the Single Transaction Translator will have 1512 bytes of periodic buffer space and 272 bytes of non-periodic buffer space (divided into 4 non-periodic buffers per TT), for a total of 1784 bytes of buffer space for the entire Transaction Translator. **Each Transaction Translator's buffer is divided as shown in Table 5.1, "Transaction Translator Buffer Chart".**

Table 5.1 Transaction Translator Buffer Chart

Periodic Start-Split Descriptors	256 Bytes
Periodic Start-Split Data	752 Bytes
Periodic Complete-Split Descriptors	128 Bytes
Periodic Complete-Split Data	376 Bytes
Non-Periodic Descriptors	16 Bytes
Non-Periodic Data	256 Bytes
Total for each Transaction Translator	1784 Bytes

5.2 Default Serial Interface Register Memory Map

The Serial Interface Registers are used to customize the USB3503 for specific applications. Reserved registers or reserved bits within a defined register should not be written to non-default values or undefined behavior may result.

Table 5.2 Serial Interface Registers

REG ADDR	R/W	REGISTER NAME	ABBREVIATION	SECTION
00h	R/W	VID LSB	VIDL	5.3.1, page 27
01h	R/W	VID MSB	VIDM	5.3.2, page 27

USB3503

Table 5.2 Serial Interface Registers (continued)

REG ADDR	R/W	REGISTER NAME	ABBREVIATION	SECTION
02h	R/W	PID LSB	PIDL	5.3.3, page 28
03h	R/W	PID MSB	PIDM	5.3.4, page 28
04h	R/W	DID LSB	DIDL	5.3.5, page 28
05h	R/W	DID MSB	DIDM	5.3.6, page 28
06h	R/W	Config Data Byte 1	CFG1	5.3.7, page 29
07h	R/W	Config Data Byte 2	CFG2	5.3.8, page 29
08h	R/W	Config Data Byte 3	CFG3	5.3.9, page 30
09h	R/W	Non-Removable Devices	NRD	5.3.10, page 31
0Ah	R/W	Port Disable (Self)	PDS	5.3.11, page 31
0Bh	R/W	Port Disable (Bus)	PDB	5.3.12, page 32
0Ch	R/W	Max Power (Self)	MAXPS	5.3.13, page 32
0Dh	R/W	Max Power (Bus)	MAXPB	5.3.14, page 32
0Eh	R/W	Hub Controller Max Current (Self)	HCMCS	5.3.15, page 33
0Fh	R/W	Hub Controller Max Current (Bus)	HCMCB	5.3.16, page 33
10h	R/W	Power-on Time	PWRT	5.3.17, page 33
11h	R/W	LANG_ID_H	LANGIDH	5.3.18, page 33
12h	R/W	LANG_ID_L	LANGIDL	5.3.19, page 33
13h	R/W	MFR_STR_LEN	MFRSL	5.3.20, page 34
14h	R/W	PRD_STR_LEN	PRDSL	5.3.21, page 34
15h	R/W	SER_STR_LEN	SERSL	5.3.22, page 34
16h-53h	R/W	MFR_STR	MANSTR	5.3.23, page 34
54h-91h	R/W	PROD_STR	PRDSTR	5.3.24, page 34
92h-CFh	R/W	SER_STR	SERSTR	5.3.25, page 35
D0h	R/W	Downstream Battery Charging	BC_EN	5.3.26, page 35
D1-E1h	R/W	Reserved	N/A	
E2h	R/W	Reserved	N/A	
E3-E4h	R/W	Reserved	N/A	
E5h	R	Port Power Status	PRTPOWER	5.3.27, page 35
E6h	R/W	Over Current Sense Control	OCS	5.3.28, page 36

Table 5.2 Serial Interface Registers (continued)

REG ADDR	R/W	REGISTER NAME	ABBREVIATION	SECTION
E7h	R/W	Serial Port Interlock Control	SP_ILOCK	5.3.29, page 36
E8h	R/W	Serial Port Interrupt Status	INT_STATUS	5.3.30, page 37
E9h	R/W	Serial Port Interrupt Mask	INT_MASK	5.3.31, page 38
EAh-EDh	R/W	Reserved	N/A	
EEh	R/W	Configure Portable Hub	CFGP	5.3.32, page 38
EFh-F3h	R	Reserved	N/A	
F4h	R/W	Varisense_Up3	VSNSUP3	5.3.33, page 39
F5h	R/W	Varisense_21	VSNS21	5.3.34, page 39
F6h	R/W	Boost_Up3	BSTUP3	5.3.35, page 39
F7h	R/W	Reserved	N/A	
F8h	R/W	Boost_21	BST21	5.3.36, page 40
F9h	R/W	Reserved	N/A	
FAh	R/W	Port Swap	PRTSP	5.3.37, page 40
FBh	R/W	Port Remap 12	PRTR12	5.3.38, page 41
FCh	R/W	Port Remap 34	PRTR34	5.3.39, page 42
FDh	R/W	Reserved	N/A	
FEh	R/W	Reserved	N/A	
FFh	R/W	I2C Status/Command	STCD	5.3.40, page 42

5.3 Serial Interface Register Definitions

5.3.1 Register 00h: Vendor ID (LSB) - VIDL

Default = 0x24h - Corresponds to Vendor ID.

BIT NUMBER	BIT NAME	DESCRIPTION
7:0	VID_LSB	Least Significant Byte of the Vendor ID. This is a 16-bit value that uniquely identifies the Vendor of the user device (assigned by USB-Interface Forum). This field is set by the customer using the serial interface options.

5.3.2 Register 01h: Vendor ID (MSB) - VIDM

Default = 0x04h - Corresponds to Vendor ID.

BIT NUMBER	BIT NAME	DESCRIPTION
7:0	VID_MSB	Most Significant Byte of the Vendor ID. This is a 16-bit value that uniquely identifies the Vendor of the user device (assigned by USB-Interface Forum). This field is set by the customer using serial interface options.

USB3503

5.3.3 Register 02h: Product ID (LSB) - PIDL

Default = 0x03h - Corresponds to USB part number for 3-port device.

BIT NUMBER	BIT NAME	DESCRIPTION
7:0	PID_LSB	Least Significant Byte of the Product ID. This is a 16-bit value that the Vendor can assign that uniquely identifies this particular product (assigned by customer). This field is set by the customer using the serial interface options.

5.3.4 Register 03h: Product ID (MSB) - PIDM

Default = 0x35h Corresponds to 3503 device.

BIT NUMBER	BIT NAME	DESCRIPTION
7:0	PID_MSB	Most Significant Byte of the Product ID. This is a 16-bit value that the Vendor can assign that uniquely identifies this particular product (assigned by customer). This field is set by the customer using the serial interface options.

5.3.5 Register 04h: Device ID (LSB) - DIDL

Default = 0xA0h

BIT NUMBER	BIT NAME	DESCRIPTION
7:0	DID_LSB	Least Significant Byte of the Device ID. This is a 16-bit device release number in BCD format (assigned by customer). This field is set by the customer using the serial interface options.

5.3.6 Register 05h: Device ID (MSB) - DIDM

Default = 0xA1h

BIT NUMBER	BIT NAME	DESCRIPTION
7:0	DID_MSB	Most Significant Byte of the Device ID. This is a 16-bit device release number in BCD format (assigned by customer). This field is set by the customer using the serial interface options.

5.3.7 Register 06h: CONFIG_BYTE_1 - CFG1

Default = 0x98h - Corresponds to Self Powered, Ganged Port Power

BIT NUMBER	BIT NAME	DESCRIPTION
7	SELF_BUS_PWR	<p>Self or Bus Power: Selects between Self- and Bus-Powered operation.</p> <p>The Hub is either Self-Powered or Bus-Powered. When configured as a Bus-Powered device, the Hub consumes less than 100mA of current prior to being configured. After configuration, the Bus-Powered Hub (along with all associated hub circuitry, any embedded devices if part of a compound device, and 100mA per externally available downstream port) must consume no more than 500mA of upstream VBUS current. The current consumption is system dependent, and the customer must ensure that the USB 2.0 specifications are not violated.</p> <p>When configured as a Self-Powered device, <1mA of upstream VBUS current is consumed and all ports are available, with each port being capable of sourcing 500mA of current.</p> <p>This field is set by the customer using the serial interface options.</p> <p>0 = Bus-Powered operation. 1 = Self-Powered operation.</p>
6	Reserved	Reserved
5	Reserved	Reserved
4	MTT_ENABLE	<p>Multi-TT enable: Enables one transaction translator per port operation.</p> <p>Selects between a mode where only one transaction translator is available for all ports (Single-TT), or each port gets a dedicated transaction translator (Multi-TT) {Note: The host may force Single-TT mode only}.</p> <p>0 = single TT for all ports. 1 = one TT per port (multiple TT's supported)</p>
3	Reserved	Reserved
2:1	CURRENT_SNS	<p>Over Current Sense: Selects current sensing on a port-by-port basis, all ports ganged, or none (only for bus-powered hubs) The ability to support current sensing on a port or ganged basis is hardware implementation dependent.</p> <p>00 = Ganged sensing (all ports together). 01 = Individual port-by-port. 1x = Over current sensing not supported. (must only be used with Bus- Powered configurations!)</p>
0	PORT_PWR	<p>Port Power Switching: Enables power switching on all ports simultaneously (ganged), or port power is individually switched on and off on a port- by-port basis (individual). The ability to support power enabling on a port or ganged basis is hardware implementation dependent.</p> <p>0 = Ganged switching (all ports together) 1 = Individual port-by-port switching.</p>

5.3.8 Register 07h: Configuration Data Byte 2 - CFG2

Default = 0x20h - Not a Compound Device

BIT NUMBER	BIT NAME	DESCRIPTION
7:4	Reserved	Reserved

USB3503

3	COMPOUND	Compound Device: Allows the customer to indicate that the Hub is part of a compound (see the USB Specification for definition) device. The applicable port(s) must also be defined as having a “Non-Removable Device”. 0 = No. 1 = Yes, Hub is part of a compound device.
2:0	Reserved	Reserved

5.3.9 Register 08h: Configuration Data Byte 3 - CFG3

Default = 0x03h

BIT NUMBER	BIT NAME	DESCRIPTION
7:4	Reserved	Reserved
3	PRTMAP_EN	Port Re-Mapping enable: Selects the method used by the hub to assign port numbers and disable ports ‘0’ = Standard Mode. The following registers are used to define which ports are enabled, and the ports are mapped as Port “n” on the hub is reported as Port ‘n’ to the host, unless one of the ports is disabled, then the higher numbered ports are remapped in order to report contiguous port numbers to the host. Section 5.3.11 Register 0A Section 5.3.12 Register 0B ‘1’ = Port Re-Map mode. The mode enables remapping via the registers defined below. Section 5.3.38 Register FB Section 5.3.39 Register FC
2:1	Reserved	Reserved
0	STRING_EN	Enables String Descriptor Support ‘0’ = String Support Disabled ‘1’ = String Support Enabled

5.3.10 Register 09h: Non-Removable Device - NRD

Default = 0x00h

BIT NUMBER	BIT NAME	DESCRIPTION
7:0	NR_DEVICE	<p>Non-Removable Device: Indicates which port(s) include non- removable devices.</p> <p>'0' = port is removable '1' = port is non- removable.</p> <p>Informs the Host if one of the active physical ports has a permanent device that is undetachable from the Hub. (Note: The device must provide its own descriptor data.)</p> <p>Bit 7= Reserved Bit 6= Reserved Bit 5= Reserved Bit 4= Reserved Bit 3= Port 3 non-removable. Bit 2= Port 2 non-removable. Bit 1= Port 1 non removable. Bit 0= Reserved</p>

5.3.11 Register 0Ah: Port Disable For Self Powered Operation - PDS

Default = 0x00h

BIT NUMBER	BIT NAME	DESCRIPTION
7:0	PORT_DIS_SP	<p>Port Disable, Self-Powered: Disables 1 or more ports.</p> <p>'0' = port is available '1' = port is disabled.</p> <p>During Self-Powered operation and PRTMAP_EN = '0', this selects the ports which will be permanently disabled, and are not available to be enabled or enumerated by a Host Controller. The ports can be disabled in any order, the internal logic will automatically report the correct number of enabled ports to the USB Host, and will reorder the active ports in order to ensure proper function.</p> <p>Bit 7= Reserved Bit 6= Reserved Bit 5= Reserved Bit 4= Reserved Bit 3= Port 3 Disable. Bit 2= Port 2 Disable. Bit 1= Port 1 Disable. Bit 0= Reserved</p>

USB3503

5.3.12 Register 0Bh: Port Disable For Bus Powered Operation - PDB

Default = 0x00h

BIT NUMBER	BIT NAME	DESCRIPTION
7:0	PORT_DIS_BP	<p>Port Disable, Bus-Powered: Disables 1 or more ports.</p> <p>'0' = port is available '1' = port is disabled.</p> <p>During Bus-Powered operation and PRTMAP_EN = '0', this selects the ports which will be permanently disabled, and are not available to be enabled or enumerated by a Host Controller. The ports can be disabled in any order, the internal logic will automatically report the correct number of enabled ports to the USB Host, and will reorder the active ports in order to ensure proper function.</p> <p>Bit 7= Reserved Bit 6= Reserved Bit 5= Reserved Bit 4= Reserved Bit 3= Port 3 Disable. Bit 2= Port 2 Disable. Bit 1= Port 1 Disable. Bit 0= Reserved</p>

5.3.13 Register 0Ch: Max Power For Self Powered Operation - MAXPS

Default = 0x01h

BIT NUMBER	BIT NAME	DESCRIPTION
7:0	MAX_PWR_SP	<p>Max Power Self_Powered: Value in 2mA increments that the Hub consumes from an upstream port when operating as a self-powered hub. This value includes the hub silicon along with the combined power consumption (from VBUS) of all associated circuitry on the board. This value also includes the power consumption of a permanently attached peripheral if the hub is configured as a compound device, and the embedded peripheral reports 0mA in its descriptors.</p> <p>Example: A value of 8mA would be written to this register as 0x04h</p> <p>Note: The USB 2.0 Specification does not permit this value to exceed 100mA</p>

5.3.14 Register 0Dh: Max Power For Bus Powered Operation - MAXPB

Default = 0xFAh- Corresponds to 500mA.

BIT NUMBER	BIT NAME	DESCRIPTION
7:0	MAX_PWR_BP	<p>Max Power Bus_Powered: Value in 2mA increments that the Hub consumes from an upstream port when operating as a bus-powered hub. This value includes the hub silicon along with the combined power consumption (from VBUS) of all associated circuitry on the board. This value also includes the power consumption of a permanently attached peripheral if the hub is configured as a compound device, and the embedded peripheral reports 0mA in its descriptors.</p> <p>Example: A value of 8mA would be written to this register as 0x04h</p>

5.3.15 Register 0Eh: Hub Controller Max Current For Self Powered Operation - HCMCS

Default = 0x02h Corresponds to 2mA.

BIT NUMBER	BIT NAME	DESCRIPTION
7:0	HC_MAX_C_SP	Hub Controller Max Current Self-Powered: Value in 1mA increments that the Hub consumes from an upstream port when operating as a self- powered hub. This value includes the hub silicon along with the combined power consumption (from VBUS) of all associated circuitry on the board. This value does NOT include the power consumption of a permanently attached peripheral if the hub is configured as a compound device. Example: A value of 8mA would be written to this register as 0x08h Note: The USB 2.0 Specification does not permit this value to exceed 100mA

5.3.16 Register 0Fh: Hub Controller Max Current For Bus Powered Operation - HCMCB

Default = 0x64h- Corresponds to 100mA.

BIT NUMBER	BIT NAME	DESCRIPTION
7:0	HC_MAX_C_BP	Hub Controller Max Current Bus-Powered: Value in 1mA increments that the Hub consumes from an upstream port when operating as a bus- powered hub. Example: A value of 8mA would be written to this register as 0x08h

5.3.17 Register 10h: Power-On Time - PWRT

Default = 0x00h - Corresponds to 0ms. Required for a hub with no power switches

BIT NUMBER	BIT NAME	DESCRIPTION
7:0	POWER_ON_TIME	Power On Time: The length of time that it takes (in 2 ms intervals) from the time the host initiated power-on sequence begins on a port until power is good on that port. System software uses this value to determine how long to wait before accessing a powered-on port. Setting affects only the hub descriptor field "PwrOn2PwrGood" see Section 7.4, "Class-Specific Hub Descriptor," on page 55.

Note: This register represents time from when a host sends a SetPortFeature(PORT_POWER) request to the time power is supplied through an external switch to a downstream port. It should be set to 0 if no power switch is used- for instance within a compound device.

5.3.18 Register 11h: Language ID High - LANGIDH

Default = 0x04h - Corresponds to US English code 0x0409h

BIT NUMBER	BIT NAME	DESCRIPTION
7:0	LANG_ID_H	USB LANGUAGE ID (Upper 8 bits of a 16 bit ID field)

5.3.19 Register 12h: Language ID Low - LANGIDL

Default = 0x09h - Corresponds to US English code 0x0409h

BIT NUMBER	BIT NAME	DESCRIPTION
7:0	LANG_ID_L	USB LANGUAGE ID (lower 8 bits of a 16 bit ID field)

USB3503

5.3.20 Register 13h: Manufacturer String Length - MFRSL

Default = 0x00h

BIT NUMBER	BIT NAME	DESCRIPTION
7:0	MFR_STR_LEN	Manufacturer String Length

5.3.21 Register 14h: Product String Length - PRDSL

Default = 0x00h

BIT NUMBER	BIT NAME	DESCRIPTION
7:0	PRD_STR_LEN	Product String Length

5.3.22 Register 15h: Serial String Length - SERSL

Default = 0x00h

BIT NUMBER	BIT NAME	DESCRIPTION
7:0	SER_STR_LEN	Serial String Length

5.3.23 Register 16h-53h: Manufacturer String - MANSTR

Default = 0x00h

BIT NUMBER	BIT NAME	DESCRIPTION
7:0	MFR_STR	Manufacturer String, UNICODE UTF-16LE per USB 2.0 Specification Note: The String consists of individual 16 Bit UNICODE UTF-16LE characters. The Characters will be stored starting with the LSB at the least significant address and the MSB at the next 8-bit location (subsequent characters must be stored in sequential contiguous address in the same LSB, MSB manner). Please pay careful attention to the Byte ordering or your selected programming tools.

5.3.24 Register 54h-91h: Product String - PRDSTR

Default = 0x00h

BIT NUMBER	BIT NAME	DESCRIPTION
7:0	PRD_STR	Product String, UNICODE UTF-16LE per USB 2.0 Specification Note: The String consists of individual 16 Bit UNICODE UTF-16LE characters. The Characters will be stored starting with the LSB at the least significant address and the MSB at the next 8-bit location (subsequent characters must be stored in sequential contiguous address in the same LSB, MSB manner). Please pay careful attention to the Byte ordering or your selected programming tools.

5.3.25 Register 92h-CFh: Serial String - SERSTR

Default = 0x00h

BIT NUMBER	BIT NAME	DESCRIPTION
7:0	SER_STR	Serial String, UNICODE UTF-16LE per USB 2.0 Specification Note: The String consists of individual 16 Bit UNICODE UTF-16LE characters. The Characters will be stored starting with the LSB at the least significant address and the MSB at the next 8-bit location (subsequent characters must be stored in sequential contiguous address in the same LSB, MSB manner). Please pay careful attention to the Byte ordering or your selected programming tools.

5.3.26 Register D0: Downstream Battery Charging Enable - BC_EN

Default = 0x00h

BIT NUMBER	BIT NAME	DESCRIPTION
7:0	BC_EN	Battery Charging Enable: Enables the battery charging feature for the corresponding downstream port. '0' = Downstream Battery Charging support is not enabled. '1' = Downstream Battery charging support is enabled Bit 7= Reserved Bit 6= Reserved Bit 5= Reserved Bit 4= Reserved Bit 3= Port 3 Battery Charging Enable. Bit 2= Port 2 Battery Charging Enable. Bit 1= Port 1 Battery Charging Enable. Bit 0= Reserved

5.3.27 Register E5h: Port Power Status - PRTPWR

Default = 0x00h

BIT NUMBER	BIT NAME	DESCRIPTION
7:4	Reserved	Reserved.
3:1	PRTPWR[3:1]	Read Only. Optional status to SOC indicating that power to the downstream port was enabled by the USB Host for the specified port. Not required for an embedded application. This is a read-only status bit. Actual control over port power is implemented by the USB Host, OCS register and Downstream Battery Charging logic if enabled. See Section 8.1.2, "Special Behavior of PRTPWR Register," on page 60 for more information. 0 = USB Host has not enabled port to be powered or in downstream battery charging and corresponding OCS bit has been set. 1 = USB Host has enabled port to be powered
0	Reserved	Reserved.

USB3503

5.3.28 Register E6h: Over Current Sense Control - OCS

Default = 0x00h

BIT NUMBER	BIT NAME	DESCRIPTION
7:4	Reserved	Reserved. {Note: Software must never write a '1' to these bits}
3	OCS[3]	When SP_ILOCK.OcsPinSel = 1 Register Bit is reserved. Setting bit has no effect on HUB operation, instead OCS_N device pin controls over current condition reporting. When SP_ILOCK.OcsPinSel = 0 Optional control from SOC on indicating external current monitor indicating an over-current condition on port 3 for HUB status reporting to USB host. Also resets corresponding PRTPWR status register bit. Not required for an embedded application. 0 = No Over Current Condition 1 = Over Current Condition
2:1	OCS[2:1]	Optional control from SOC on indicating external current monitor indicating an over-current condition on the specified port for HUB status reporting to USB host. Also resets corresponding PRTPWR status register bit. Not required for an embedded application. 0 = No Over Current Condition 1 = Over Current Condition
0	Reserved	Reserved.

5.3.29 Register E7h: Serial Port Interlock Control - SP_ILOCK

Default=0x32h - Corresponds to OCS_N/PRT_PWR pins & pausing to connect until write from I2C

BIT NUMBER	BIT NAME	DESCRIPTION
7:6	Reserved	Reserved
5	OcsPinSel	1= OCS device pin will assume role as an active low Over Current Sense input 0= OCS device pin disabled, register control established
4	PrtPwrPinSel	1=PRTPWR device pin will assume role as an active high Port Power Switch Control output 0=PRTPWR device pin disabled, register control established
3:2	Reserved	Reserved

BIT NUMBER	BIT NAME	DESCRIPTION
1	connect_n	<p>The SOC can utilize this bit to control when the hub attempts to connect to the upstream host.</p> <p>1 = Device will remain in Hub Mode.Connect Stage indefinitely until bit is cleared by the SOC. 0 = Device will transition to the Hub Mode.Communication Stage after this bit is asserted low by default or through a serial port write.</p>
0	config_n	<p>If the SOC intends to update the default configuration using the serial port, this register should be the first register updated by the SOC. In this way the timing dependency between configuration and device operation can be minimized- the SOC is only required to write to Serial Port Interlock Register within $T_{hubconfig}$ and not all the registers it is attempting to configure.</p> <p>Once all registers have been written for the desired configuration, the SOC must clear this bit to '0' for the device to resume normal operation using the new configuration.</p> <p>It may be desirable for the device to initiate autonomous operation with no SOC intervention at all. This is why the default setting is to allow the device to initiate automatic operation if the SOC does not intervene by writing the interlock register within the allotted configuration timeout.</p> <p>1 = Device will remain in Hub Mode.Configuration Stage indefinitely, and allow SOC to write through the serial port to set any desired configuration. 0 = Device will transition out of Hub.Configuration Stage immediately after this bit is asserted low through a serial port write. (A default low assertion results in transition after a timeout.)</p>

5.3.30 Register E8h: Serial Port Interrupt Status - INT_STATUS

Default = 0x00h

BIT NUMBER	BIT NAME	DESCRIPTION
7	Interrupt	<p>Read: 1 = INT_N pin has been asserted low due to unmasked interrupt 0 = INT_N pin has not been asserted low due to unmasked interrupt</p> <p>Write: 1 = No Effect – INT_N pin and register retains its current value 0 = Negate INT_N pin high</p>
6:5	Reserved	Reserved
4	HubSusplnt	<p>Read: 1 = Hub has entered USB suspend 0 = Hub has not entered USB suspend since last HubSusplnt reset</p> <p>Write: 1 = No Effect 0 = Negate HubSusplnt status low</p>
3	HubCfgInt	<p>Read: 1 = Hub has been configured by USB Host 0 = Hub has not been configured by USB Host since last HubConflnt reset</p> <p>Write: 1 = No Effect 0 = Negate HubConflnt status low</p>
2	PrtPwrInt	<p>Read: 1 = Port Power register has been updated 0 = Port Power register has not been updated since last PrtPwrInt reset</p> <p>Write: 1 = No Effect 0 = Negate PrtPwrInt status low</p>
1:0	Reserved	Reserved

USB3503

5.3.31 Register E9h: Serial Port Interrupt Mask - INT_MASK

Default = 0x00h

BIT NUMBER	BIT NAME	DESCRIPTION
7:5	Reserved	Reserved
4	HubSuspMask	1 = INT_N pin is asserted low when Hub enters suspend 0 = INT_N pin is not affected by Hub entering suspend
3	HubCfgMask	1 = INT_N pin is asserted low when Hub configured by USB Host 0 = INT_N pin is not affected by Hub configuration event
2	PrtPwrMask	1 = INT_N pin is asserted low when Port Power register has been updated by USB Host 0 = INT_N pin is not affected by Port Power register
1:0	Reserved	Reserved

5.3.32 Register EEh: Configure Portable Hub - CFGP

Default = 0x00h - Corresponds to 95ms startup & Phone RefClks available

BIT NUMBER	BIT NAME	DESCRIPTION
7	ClkSusp	(Read/Write) 1 = Force device to run internal clock even during USB suspend (will cause device to violate USB suspend current limit - intended for test or self-powered applications which require use of serial port during USB session.) 0 = Allow device to gate off its internal clocks during suspend mode in order to meet USB suspend current requirements.
6	IntSusp	(Read/Write) 1 = INT_N pin function is a level sensitive USB suspend interrupt indication. Allows system to adjust current consumption to comply with USB specification limits when hub is in the USB suspend state. 0 = INT_N pin function retains event sensitive role of a general serial port interrupt. See Section 3.3.4, "Interrupt," on page 19 for more information.
5:4	CfgTout	(Read Only) Specifies timeout value for allowing SOC to configure the device. Corresponds to the $T_{hubconfig}$ parameter. See Section Table 4.2, "Timing Parameters for Hub Stages" . '00' = 95ms - Use to meet legacy 100ms connect timing
3	Reserved	Reserved
2:0	Reserved	Reserved

5.3.33 Register F4h: Varisense_UP3 - VSNSUP3

Default = 0x00h

BIT NUMBER	BIT NAME	DESCRIPTION
7:3	Reserved	Reserved
2:0	DN3_SQUELCH	These two bits control the Squelch setting of the downstream port 3. '000' = Nominal value '001' = 90% of Nominal value '010' = 80% of Nominal value '011' = 70% of Nominal value '100' = 60% of Nominal value '101' = 50% of Nominal value '110' = 120% of Nominal value '111' = 110% of Nominal value

5.3.34 Register F5h: Varisense_21 - VSNS21

Default = 0x00h

BIT NUMBER	BIT NAME	DESCRIPTION
7	Reserved	Reserved
6:4	DN2_SQUELCH	These two bits control the Squelch setting of the downstream port 2. '000' = Nominal value '001' = 90% of Nominal value '010' = 80% of Nominal value '011' = 70% of Nominal value '100' = 60% of Nominal value '101' = 50% of Nominal value '110' = 120% of Nominal value '111' = 110% of Nominal value
3	Reserved	Reserved
2:0	DN1_SQUELCH	These three bits control the Squelch setting of the downstream port 1. '000' = Nominal value '001' = 90% of Nominal value '010' = 80% of Nominal value '011' = 70% of Nominal value '100' = 60% of Nominal value '101' = 50% of Nominal value '110' = 120% of Nominal value '111' = 110% of Nominal value

5.3.35 Register F6h: Boost_Up3 - BSTUP3

Default = 0x30h

BIT NUMBER	BIT NAME	DESCRIPTION
7:3	Reserved	Reserved
2:0	BOOST_IOUT_3	USB electrical signaling drive strength Boost Bit for Downstream Port '3'. Boosts USB High Speed Current. 3'b000: Nominal 3'b001: -5% 3'b010: +10% 3'b011: +5% 3'b100: +20% 3'b101: +15% 3'b110: +30% 3'b111: +25%

USB3503

5.3.36 Register F8h: Boost_21 - BST21

Default = 0x00h

BIT NUMBER	BIT NAME	DESCRIPTION
7	Reserved	Reserved
6:4	BOOST_IOUT_2	<p>USB electrical signaling drive strength Boost Bit for Downstream Port '2'. Boosts USB High Speed Current.</p> <p>3'b000: Nominal 3'b001: -5% 3'b010: +10% 3'b011: +5% 3'b100: +20% 3'b101: +15% 3'b110: +30% 3'b111: +25%</p>
3	Reserved	Reserved
2:0	BOOST_IOUT_1	<p>USB electrical signaling drive strength Boost Bit for Downstream Port '1'. Boosts USB High Speed Current.</p> <p>3'b000: Nominal 3'b001: -5% 3'b010: +10% 3'b011: +5% 3'b100: +20% 3'b101: +15% 3'b110: +30% 3'b111: +25%</p>

5.3.37 Register FAh: Port Swap - PRTSP

Default = 0x00h

BIT NUMBER	BIT NAME	DESCRIPTION
7:0	PRTSP	<p>Port Swap: Swaps the Upstream HSIC and Downstream USB DP and DM Pins for ease of board routing to devices and connectors.</p> <p>'0' = USB D+ functionality is associated with the DP pin and D- functionality is associated with the DM pin. '1' = USB D+ functionality is associated with the DM pin and D- functionality is associated with the DP pin.</p> <p>Bit 7= Reserved Bit 6= Reserved Bit 5= Reserved Bit 4= Reserved Bit 3= Port 3 DP/DM Swap. Bit 2= Port 2 DP/DM Swap. Bit 1= Port 1 DP/DM Swap. Bit 0= Reserved</p>

5.3.38 Register FBh: Port Remap 12 - PRTR12

Default = 0x21h - Physical Port is mapped to the corresponding logical port.

BIT NUMBER	BIT NAME	DESCRIPTION																																				
7:0	PRTR12	<p>Port remap register for ports 1 & 2.</p> <p>When a hub is enumerated by a USB Host Controller, the hub is only permitted to report how many ports it has, the hub is not permitted to select a numerical range or assignment. The Host Controller will number the downstream ports of the hub starting with the number '1', up to the number of ports that the hub reported having.</p> <p>The host's port number is referred to as "Logical Port Number" and the physical port on the hub is the Physical Port Number". When remapping mode is enabled (see PRTMAP_EN in Section 5.3.9) the hub's downstream port numbers can be remapped to different logical port numbers (assigned by the host.)</p> <p>Note: the customer must ensure that Contiguous Logical Port Numbers are used, starting from #1 up to the maximum number of enabled ports, this ensures that the hub's ports are numbered in accordance with the way a Host will communicate with the ports.</p> <table border="1" data-bbox="594 806 1453 1291"> <tbody> <tr> <td data-bbox="594 806 727 840">Bit [7:4] =</td> <td data-bbox="727 806 808 840">'0000'</td> <td data-bbox="808 806 1453 840">Physical Port 2 is Disabled</td> </tr> <tr> <td></td> <td data-bbox="727 840 808 873">'0001'</td> <td data-bbox="808 840 1453 873">Physical Port 2 is mapped to Logical Port 1</td> </tr> <tr> <td></td> <td data-bbox="727 873 808 907">'0010'</td> <td data-bbox="808 873 1453 907">Physical Port 2 is mapped to Logical Port 2</td> </tr> <tr> <td></td> <td data-bbox="727 907 808 940">'0011'</td> <td data-bbox="808 907 1453 940">Physical Port 2 is mapped to Logical Port 3</td> </tr> <tr> <td></td> <td data-bbox="727 940 808 974">'0100'</td> <td data-bbox="808 940 1453 974">Reserved, will default to '0000' value</td> </tr> <tr> <td></td> <td data-bbox="727 974 808 1050">'0101' to '1111'</td> <td data-bbox="808 974 1453 1050">Reserved, will default to '0000' value</td> </tr> <tr> <td data-bbox="594 1050 727 1083">Bit [3:0] =</td> <td data-bbox="727 1050 808 1083">'0000'</td> <td data-bbox="808 1050 1453 1083">Physical Port 1 is Disabled</td> </tr> <tr> <td></td> <td data-bbox="727 1083 808 1117">'0001'</td> <td data-bbox="808 1083 1453 1117">Physical Port 1 is mapped to Logical Port 1</td> </tr> <tr> <td></td> <td data-bbox="727 1117 808 1150">'0010'</td> <td data-bbox="808 1117 1453 1150">Physical Port 1 is mapped to Logical Port 2</td> </tr> <tr> <td></td> <td data-bbox="727 1150 808 1184">'0011'</td> <td data-bbox="808 1150 1453 1184">Physical Port 1 is mapped to Logical Port 3</td> </tr> <tr> <td></td> <td data-bbox="727 1184 808 1218">'0100'</td> <td data-bbox="808 1184 1453 1218">Reserved, will default to '0000' value</td> </tr> <tr> <td></td> <td data-bbox="727 1218 808 1291">'0101' to '1111'</td> <td data-bbox="808 1218 1453 1291">Reserved, will default to '0000' value</td> </tr> </tbody> </table>	Bit [7:4] =	'0000'	Physical Port 2 is Disabled		'0001'	Physical Port 2 is mapped to Logical Port 1		'0010'	Physical Port 2 is mapped to Logical Port 2		'0011'	Physical Port 2 is mapped to Logical Port 3		'0100'	Reserved, will default to '0000' value		'0101' to '1111'	Reserved, will default to '0000' value	Bit [3:0] =	'0000'	Physical Port 1 is Disabled		'0001'	Physical Port 1 is mapped to Logical Port 1		'0010'	Physical Port 1 is mapped to Logical Port 2		'0011'	Physical Port 1 is mapped to Logical Port 3		'0100'	Reserved, will default to '0000' value		'0101' to '1111'	Reserved, will default to '0000' value
Bit [7:4] =	'0000'	Physical Port 2 is Disabled																																				
	'0001'	Physical Port 2 is mapped to Logical Port 1																																				
	'0010'	Physical Port 2 is mapped to Logical Port 2																																				
	'0011'	Physical Port 2 is mapped to Logical Port 3																																				
	'0100'	Reserved, will default to '0000' value																																				
	'0101' to '1111'	Reserved, will default to '0000' value																																				
Bit [3:0] =	'0000'	Physical Port 1 is Disabled																																				
	'0001'	Physical Port 1 is mapped to Logical Port 1																																				
	'0010'	Physical Port 1 is mapped to Logical Port 2																																				
	'0011'	Physical Port 1 is mapped to Logical Port 3																																				
	'0100'	Reserved, will default to '0000' value																																				
	'0101' to '1111'	Reserved, will default to '0000' value																																				

USB3503

5.3.39 Register FCh: Port Remap 34 - PRTR34

Default = 0x03h - Physical port is mapped to corresponding logical port.

BIT NUMBER	BIT NAME	DESCRIPTION
7:0	PRTR34	<p>Port remap register for ports 3.</p> <p>When a hub is enumerated by a USB Host Controller, the hub is only permitted to report how many ports it has, the hub is not permitted to select a numerical range or assignment. The Host Controller will number the downstream ports of the hub starting with the number '1', up to the number of ports that the hub reported having.</p> <p>The host's port number is referred to as "Logical Port Number" and the physical port on the hub is the Physical Port Number". When remapping mode is enabled (see PRTMAP_EN in Section 5.3.9) the hub's downstream port numbers can be remapped to different logical port numbers (assigned by the host).</p> <p>Note: the customer must ensure that Contiguous Logical Port Numbers are used, starting from #1 up to the maximum number of enabled ports, this ensures that the hub's ports are numbered in accordance with the way a Host will communicate with the ports.</p>
	Bit [7:4] =	'0000' Reserved – software must not write '1' to any of these bits.
		'0001' to '1111' Reserved, will default to '0000' value
	Bit [3:0] =	'0000' Physical Port 3 is Disabled
		'0001' Physical Port 3 is mapped to Logical Port 1
		'0010' Physical Port 3 is mapped to Logical Port 2
		'0011' Physical Port 3 is mapped to Logical Port 3
		'0100' Reserved, will default to '0000' value Physical Port 3 is mapped to Logical Port 4
		'0101' to '1111' Reserved, will default to '0000' value

5.3.40 Register FFh: Status/Command - STCD

Default = 0x00h

BIT NUMBER	BIT NAME	DESCRIPTION
7:2	Reserved	Reserved {Note: Software must never write a '1' to these bits}
1	RESET	<p>Reset the Serial Interface and internal memory registers in address range 00h-E1h and EFh-FFh back to RESET_N assertion default settings. {Note: During this reset, this bit is automatically cleared to its default value of 0.}</p> <p>0 = Normal Run/Idle State. 1 = Force a reset of the registers to their default state.</p>
0	CONFIG_PROTECT	<p>Protect the Configuration</p> <p>0 = serial slave interface is active. 1 = The internal configuration memory (address range 00h-E1h and EFh-FFh) is "write-protected" to prevent unintentional data corruption.</p> <p>{Note 1: This bit is write once and is only cleared by assertion of the external RESET_N pin.}</p>

USB3503

Chapter 6 Serial Slave Interface

6.1 Overview

The serial slave interface on USB3503 is implemented as I²C. It is a standard I²C slave interface that operates at the standard (100Kbps), fast (400Kbps), and the fast mode plus (1Mbps) modes.

The USB3503 I²C slave interface address is 0x08h.

REFCLK must be running for I²C to operate. The register map is outlined in section [Section 5.3](#).

The I²C Slave Base Address is 0x08. The interrupt pin INT_N is used to communicate status changes on selected events that are mapped into the Serial Port Interrupt Status Register. INT_N is asserted low whenever an unmasked bit is set in the Serial Port Interrupt Status Register. SOC must update the Serial Port Interrupt Status Register to negate the interrupt high.

The SOC can mask events to not cause the interrupt pin to transition by updating the Serial Port Interrupt Mask Register. The status events will still be captured in the status register even if the interrupt pin is not asserted. The serial port has limited speed and latency capability so events mapped into the serial ports and its interrupt are not expected to be latency critical.

6.2 Interconnecting the USB3503 to an I²C Master

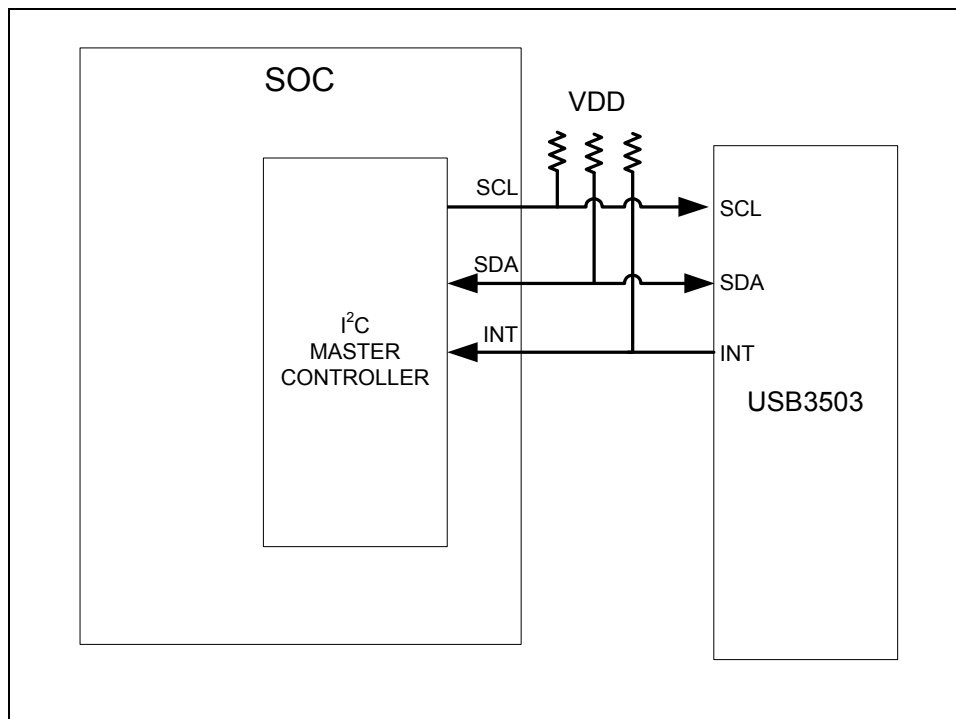

Figure 6.1 I²C Connections

Note 6.1 The largest pullup values which meet the customer application should be selected in order to minimize power consumption. Pullup values must also have low enough resistance to support the desired I²C operating speed with the expected total capacitance in the application. Typical applications are expected to use pullup values between 220Ω and 2.7kΩ for operation at 1MHz on SCL and SDA. Larger pullup resistors may be acceptable for operation at 400KHz or 100KHz.

6.3 I²C Message format

6.3.1 Sequential Access Writes

The I²C interface will support sequential writing of the register address space of the USB3503. This mode is useful for configuring contiguous blocks of registers. Please see section on SOC interface for address definitions. Figure 6.2 shows the format of the sequential write operation. Where color is visible in the figure, blue indicates signaling from the I²C master, and gray indicates signaling from the USB3503 slave:

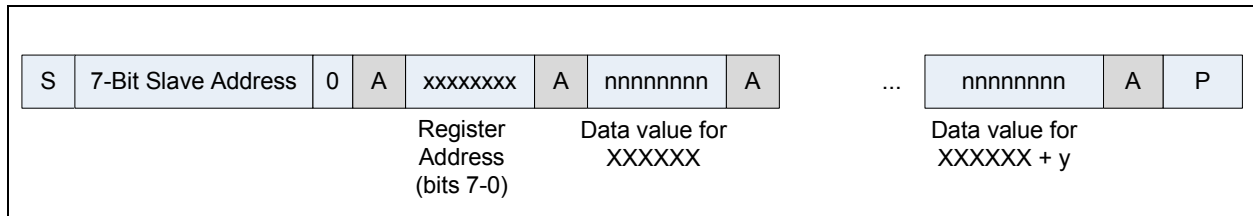

Figure 6.2 I²C Sequential Access Write Format

In this operation, following the 7-bit slave address, an 8-bit register address is written indicating the start address for sequential write operation. Every data access after that is a data write to a data register where the register address increments after each access and ACK from the slave must occur. Sequential write access is terminated by a Stop condition.

6.3.2 Sequential Access Reads

The I²C interface will support direct reading of the USB3503 registers. In order to read one or more register addresses, the starting address must be set by using a write sequence followed by a read. The read register interface supports auto-increment mode. The master should send a NACK instead of an ACK when the last byte has been transferred.

In this operation, following the 7-bit slave address, 8-bit register address is written indicating the start address for sequential read operation to be followed. In the read sequence, every data access is a data read from a data register where the register address increments after each access. Write sequence can end with optional Stop (P). If so the Read sequence must start with a Start (S) otherwise it must start with Repeated Start (Sr).

Figure 6.3 shows the format of the read operation. Where color is visible in the figure, blue and gold indicate signaling from the I²C master, and gray indicates signaling from the USB3503 slave.

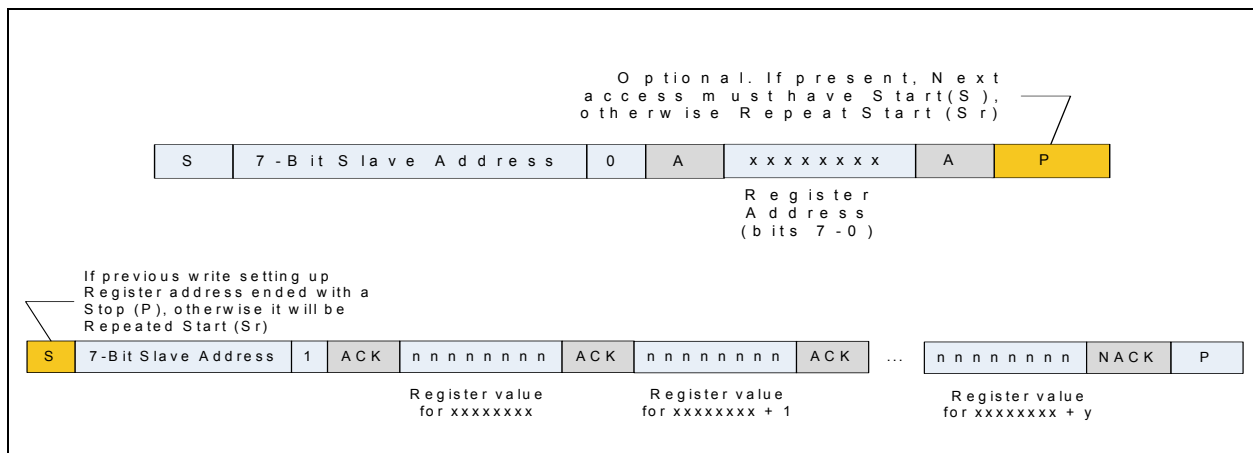

Figure 6.3 Sequential Access Read Format

USB3503

6.3.3 I²C Timing

Below is the timing diagram and timing specifications for the different I²C modes that the USB3503 supports.

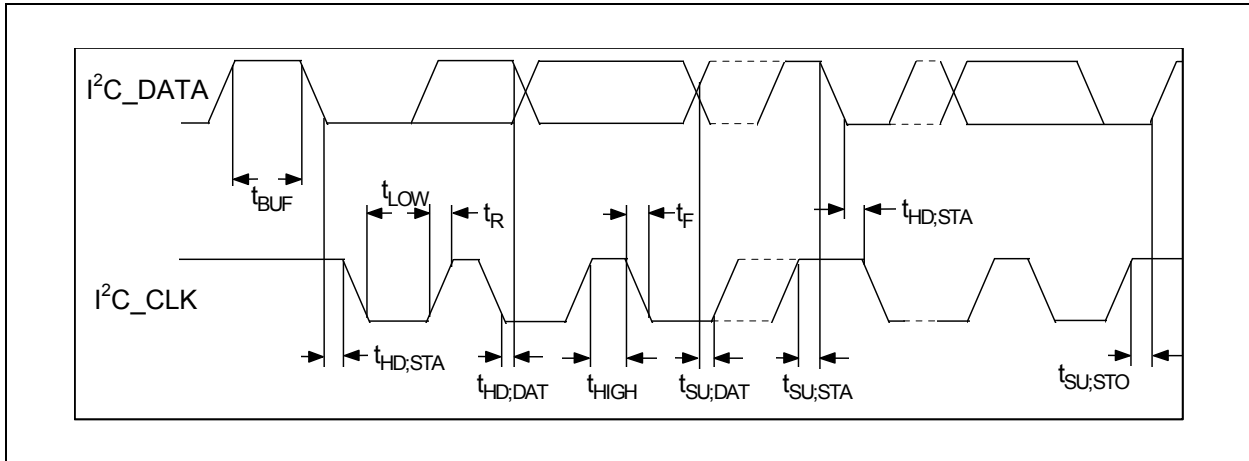

Figure 6.4 I²C Timing Diagram

Table 6.1 I²C Timing Specifications

SYMBOL	PARAMETER	STANDARD-MODE		FAST-MODE		FAST-MODE PLUS		UNIT
		MIN	MAX	MIN	MAX	MIN	MAX	
f _{SCL}	SCL clock frequency	0	100	0	400	0	1000	KHz
t _{HD,STA}	Hold time START condition	4		0.6		0.26		μs
t _{LOW}	LOW period of the SCL clock	4.7		1.3		0.5		μs
t _{HIGH}	HIGH period of the SCL clock	4		0.6		0.26		μs
t _{SU,STA}	Set-up time for a repeated START condition	4.7		0.6		0.26		μs
t _{HD,DAT}	DATA hold time	0		0		0		ns
t _{SU,DAT}	DATA set-up time	250		100		50		ns
t _R	Rise time of both SDA and SCL signals		1000		300		120	ns
t _F	Fall time of both SCL and SDA lines		300		300		120	ns

Table 6.1 I²C Timing Specifications (continued)

SYMBOL	PARAMETER	STANDARD-MODE		FAST-MODE		FAST-MODE PLUS		UNIT
		MIN	MAX	MIN	MAX	MIN	MAX	
t _{SU;STO}	Set-up time for a STOP condition	4		0.6		0.26		μs
t _{BUF}	Bus free time between a STOP and START condition	4.7		1.3		0.5		μs

USB3503

Chapter 7 USB Descriptors

A customer can indirectly affect which descriptors are reported via one of two methods. The two methods are: Internal Default ROM Configuration, or direct load through the serial port interface.

The Hub will not electrically attach to the USB until after it has loaded valid data for all user- defined descriptor fields (either through Internal Default ROM, or serial port).

7.1 USB Bus Reset

In response to the upstream port signaling a reset to the Hub, the Hub does the following:

Note 7.1 The Hub does not propagate the upstream USB reset to downstream devices.

- Sets default address to 0.
- Sets configuration to: Unconfigured.
- Negates PRTPWR[3:1] register for all downstream ports.
- Clears all TT buffers.
- Moves device from suspended to active (if suspended).
- Complies with Section 11.10 of the USB 2.0 Specification for behavior after completion of the reset sequence.

The Host then configures the Hub and the Hub's downstream port devices in accordance with the USB Specification.

7.2 Hub Attached as a High-Speed Device (Customer-Configured for Single-TT Support Only)

The following tables provide descriptor information for Customer-Configured Single-TT-Only Hubs attached for use with High-Speed devices.

7.2.1 Standard Device Descriptor

The following table provides device descriptor values for High-Speed operation.

Table 7.1 Device Descriptor

OFFSET	FIELD	SIZE	VALUE	DESCRIPTION
0	Length	1	12h	Size of this Descriptor.
1	DescriptorType	1	01h	Device Descriptor Type.
2	USB	2	0200h	USB Specification Release Number.
4	DeviceClass	1	09h	Class code assigned by USB-IF for Hubs.
5	DeviceSubClass	1	00h	Class code assigned by USB-IF for Hubs.
6	DeviceProtocol	1	01h	Protocol Code.
7	MaxPacketSize0	1	40h	64-byte packet size.
8	Vendor	2	user/ default	Vendor ID; Customer value defined in ROM or serial port load.
10	Product	2	user/ default	Product ID; Customer value defined in ROM or serial port load.

Table 7.1 Device Descriptor (continued)

OFFSET	FIELD	SIZE	VALUE	DESCRIPTION
12	Device	2	user/ default	Device ID; Customer value defined in ROM or serial port load
14	Manufacturer	1	xxh	If STRING_EN =0 Optional string is not supported, and xx = 00. If STRING_EN = 1, String support is enabled, and xx = 01
15	Product	1	yyh	If STRING_EN =0 Optional string is not supported, and yy = 00. If STRING_EN = 1, String support is enabled, and yy = 02
16	SerialNumber	1	zzh	If STRING_EN =0 Optional string is not supported, and zz = 00. If STRING_EN = 1, String support is enabled, and zz = 03
17	NumConfigurations	1	01h	Supports 1 configuration.

7.2.2 Configuration Descriptor

The following table provides configuration descriptor values for High-Speed, Single-TT-Only operation.

Table 7.2 Configuration Descriptor (High-Speed, Single-TT Only)

OFFSET	FIELD	SIZE	VALUE	DESCRIPTION
0	Length	1	09h	Size of this Descriptor.
1	DescriptorType	1	02h	Configuration Descriptor Type.
2	TotalLength	2	yyyyh	Total combined length of all descriptors for this configuration (configuration, interface, endpoint, and class- or vendor-specific). yyyyh = 0019h
4	NumInterfaces	1	01h	Number of interfaces supported by this configuration.
5	ConfigurationValue	1	01H	Value to use as an argument to the SetConfiguration() request to select this configuration.
6	Configuration	1	00h	Index of string descriptor describing this configuration (string not supported).
7	Attributes	1	user/ signal	Configuration characteristics: Communicates the capabilities of the hub regarding Remote Wake-up capability, and also reports the self-power status. In all cases, the value reported to the host always indicates that the hub supports Remote Wakeup. The value reported to the host is dependant upon the SELF_BUS_PWR bit (CONFIG_BYTE_1) = A0h for Bus-Powered (SELF_BUS_PWR = 0). = E0h for Self-Powered (SELF_BUS_PWR = 1). All other values are reserved.

USB3503

Table 7.2 Configuration Descriptor (High-Speed, Single-TT Only) (continued)

OFFSET	FIELD	SIZE	VALUE	DESCRIPTION
8	MaxPower	1	user	<p>Maximum Power Consumption of the Hub from VBUS when fully operational. This value includes all support circuitry associated with the hub (including an attached “embedded” peripheral if hub is part of a compound device), and is in 2mA increments. The Hub supports Self-Powered and Bus-Powered operation. The SELF_BUS_PWR bit (CONFIG_BYTE_1) is used to determine which of the values below are reported. The value reported to the host must coincide with the current operating mode, and will be determined by the following rules.</p> <p>The value that is reported to the host will be:</p> <p>‘MAX_PWR_BP’ if SELF_BUS_PWR = ‘0’ ‘MAX_PWR_SP’ if SELF_BUS_PWR = ‘1’</p> <p>In all cases the reported value is sourced from the MAX POWER data field (for Self or Bus power) that was loaded by Internal Default, or serial port configuration.</p>

7.2.3 Interface Descriptor (Single-TT)

The following table provides interface descriptor values for High-Speed, Single-TT operation.

Table 7.3 Interface Descriptor (High-Speed, Single-TT)

OFFSET	FIELD	SIZE	VALUE	DESCRIPTION
0	Length	1	09h	Size of this Descriptor.
1	DescriptorType	1	04h	Interface Descriptor Type.
2	InterfaceNumber	1	00h	Number of this interface.
3	AlternateSetting	1	00h	Value used to select this alternate setting for the interface.
4	NumEndpoints	1	01h	Number of endpoints used by this interface (not including endpoint 0).
5	InterfaceClass	1	09h	Hub class code.
6	InterfaceSubclass	1	00h	Subclass code.
7	InterfaceProtocol	1	00h	Single-TT.
8	Interface	1	00h	Index of the string descriptor describing this interface (strings not supported).

7.2.4 Endpoint Descriptor (Single-TT)

The following table provides endpoint descriptor values for Single-TT operation.

Table 7.4 Endpoint Descriptor (For Status Change Endpoint, Single-TT)

OFFSET	FIELD	SIZE	VALUE	DESCRIPTION
0	Length	1	07h	Size of this Descriptor.
1	DescriptorType	1	05h	Endpoint Descriptor Type.
2	EndpointAddress	1	81h	The address of the endpoint on the USB device.
3	Attributes	1	03h	Describes the endpoint's attributes. (interrupt only, no synchronization, data endpoint).
4	MaxPacketSize	2	0001h	Maximum packet size for this endpoint.
6	Interval	1	0Ch	Interval for polling endpoint for data transfers (Maximum Possible).

7.3 Hub Attached as a High-Speed Device (Customer-Configured as Multi-TT Capable)

The following tables provide descriptor information for Customer-Configured Multi-TT High-Speed devices.

7.3.1 Standard Device Descriptor

The following table provides device descriptor values for High-Speed operation.

Table 7.5 Device Descriptor (High-Speed)

OFFSET	FIELD	SIZE	VALUE	DESCRIPTION
0	Length	1	12	Size of this Descriptor
1	DescriptorType	1	01h	Device Descriptor Type.
2	USB	2	0200h	USB Specification Release Number.
4	DeviceClass	1	09h	Class code assigned by USB-IF for Hubs.
5	DeviceSubClass	1	00h	Class code assigned by USB-IF for Hubs.
6	DeviceProtocol	1	02h	Protocol code (Multi-TTs).
7	MaxPacketSize0	1	40h	64-byte packet size.
8	Vendor	2	user	Vendor ID; Customer value defined in ROM or serial port load.
10	Product	2	user	Product ID; Customer value defined in ROM or serial port load.
12	Device	2	user	Device ID; Customer value defined in ROM or serial port load.

USB3503

Table 7.5 Device Descriptor (High-Speed) (continued)

OFFSET	FIELD	SIZE	VALUE	DESCRIPTION
14	Manufacturer	1	xxh	If STRING_EN =0 Optional string is not supported, and xx = 00. If STRING_EN = 1, String support is enabled, and xx = 01
15	Product	1	yyh	If STRING_EN =0 Optional string is not supported, and yy = 00. If STRING_EN = 1, String support is enabled, and yy = 02
16	SerialNumber	1	zzh	If STRING_EN =0 Optional string is not supported, and zz = 00. If STRING_EN = 1, String support is enabled, and zz = 03
17	NumConfigurations	1	01h	Supports 1 configuration.

7.3.2 Configuration Descriptor

The following table provides configuration descriptor values for High-Speed operation.

Table 7.6 Configuration Descriptor (High-Speed)

OFFSET	FIELD	SIZE	VALUE	DESCRIPTION
0	Length	1	09h	Size of this Descriptor.
1	DescriptorType	1	02h	Configuration Descriptor Type.
2	TotalLength	2	yyyyh	Total combined length of all descriptors for this configuration (configuration, interface, endpoint, and class- or vendor-specific). yyyyh = 0029h.
4	NumInterfaces	1	01h	Number of Interface supported by this configuration.
5	ConfigurationValue	1	01H	Value to use as an argument to the SetConfiguration() request to select this configuration.
6	Configuration	1	00h	Index of string descriptor describing this configuration (String not supported).
7	Attributes	1	user/ signal	Configuration characteristics: Communicates the capabilities of the hub regarding Remote Wake-up capability, and also reports the self-power status. In all cases, the value reported to the host always indicates that the hub supports Remote Wakeup. The value reported to the host is dependant upon the SELF_BUS_PWR bit (CONFIG_BYTE_1) = A0h for Bus-Powered (SELF_BUS_PWR = 0). = E0h for Self-Powered (SELF_BUS_PWR = 1). All other values are reserved.

Table 7.6 Configuration Descriptor (High-Speed) (continued)

OFFSET	FIELD	SIZE	VALUE	DESCRIPTION
8	MaxPower	1	user	<p>Maximum Power Consumption of the Hub from VBUS when fully operational. This value includes all support circuitry associated with the hub (including an attached “embedded” peripheral if hub is part of a compound device), and is in 2mA increments. The Hub supports Self-Powered and Bus-Powered operation. The SELF_BUS_PWR bit (CONFIG_BYTE_1) is used to determine which of the values below are reported. The value reported to the host must coincide with the current operating mode, and will be determined by the following rules.</p> <p>The value that is reported to the host will be:</p> <p>‘MAX_PWR_BP’ if SELF_BUS_PWR = ‘0’ ‘MAX_PWR_SP’ if SELF_BUS_PWR = ‘1’</p> <p>In all cases the reported value is sourced from the MAX POWER data field (for Self or Bus power) that was loaded by Internal Default, or serial port configuration.</p>

7.3.3 Interface Descriptor (Single-TT)

The following table provides interface descriptor values for High-Speed Single-TT operation.

Table 7.7 Interface Descriptor (High-Speed, Single-TT)

OFFSET	FIELD	SIZE	VALUE	DESCRIPTION
0	Length	1	09h	Size of this Descriptor.
1	DescriptorType	1	04h	Interface Descriptor Type.
2	InterfaceNumber	1	00h	Number of this interface.
3	AlternateSetting	1	00h	Value used to select this alternate setting for the interface.
4	NumEndpoints	1	01h	Number of endpoints used by this interface (not including endpoint 0).
5	InterfaceClass	1	09h	Hub class code.
6	InterfaceSubclass	1	00h	Subclass code
7	InterfaceProtocol	1	01h	Single-TT.
8	Interface	1	00h	Index of the string descriptor describing this interface (strings not supported).

7.3.4 Endpoint Descriptor (Single-TT)

The following table provides endpoint descriptor values for Single-TT operation.

USB3503

Table 7.8 Endpoint Descriptor (For Status Change Endpoint, Single-TT)

OFFSET	FIELD	SIZE	VALUE	DESCRIPTION
0	Length	1	07h	Size of this Descriptor.
1	DescriptorType	1	05h	Endpoint Descriptor Type.
2	EndpointAddress	1	81h	The address of the endpoint on the USB device.
3	Attributes	1	03h	Describes the endpoint's attributes. (interrupt only, no synchronization, data endpoint).
4	MaxPacketSize	2	0001h	Maximum packet size for this endpoint.
6	Interval	1	0Ch	Interval for polling endpoint for data transfers (Maximum Possible).

7.3.5 Interface Descriptor (Multi-TT)

The following table provides interface descriptor values for High-Speed Multi-TT operation.

Table 7.9 Interface Descriptor (Multi-TT, High-Speed)

OFFSET	FIELD	SIZE	VALUE	DESCRIPTION
0	Length	1	09h	Size of this Descriptor.
1	DescriptorType	1	04h	Interface Descriptor Type.
2	InterfaceNumber	1	00h	Number of this interface.
3	AlternateSetting	1	01h	Value used to select this alternate setting for the interface.
4	NumEndpoints	1	01h	Number of endpoints used by this interface (not including endpoint 0).
5	InterfaceClass	1	09h	Hub class code.
6	InterfaceSubclass	1	00h	Subclass code.
7	InterfaceProtocol	1	02h	Multiple-TTs.
8	Interface	1	00h	Index of the string descriptor describing this interface (strings not supported).

7.3.6 Endpoint Descriptor (Multi-TT)

The following table provides endpoint descriptor values for Multi-TT operation.

Table 7.10 EndPoint Descriptor (For Status Change Endpoint, Multi-TT)

OFFSET	FIELD	SIZE	VALUE	DESCRIPTION
0	Length	1	07h	Size of this Descriptor.
1	DescriptorType	1	05h	Endpoint Descriptor Type.
2	EndpointAddress	1	81h	The address of the endpoint on the USB device.

Table 7.10 EndPoint Descriptor (For Status Change Endpoint, Multi-TT) (continued)

OFFSET	FIELD	SIZE	VALUE	DESCRIPTION
3	Attributes	1	03h	Describes the endpoint's attributes. (interrupt only, no synchronization, data endpoint).
4	MaxPacketSize	2	0001h	Maximum packet size for this endpoint.
6	Interval	1	0Ch	Interval for polling endpoint for data transfers (Maximum Possible).

7.4 Class-Specific Hub Descriptor

The following table provides class-specific Hub descriptor values.

Note: The Hub must respond to Hub Class Descriptor type 29h (the USB 1.1 and USB 2.0 value) and 00h (the USB 1.0 value).

Table 7.11 Class-Specific Hub Descriptor

OFFSET	FIELD	SIZE	VALUE	DESCRIPTION
0	Length	1	09h	Size of this Descriptor.
1	DescriptorType	1	29h	Hub Descriptor Type.
2	NbrPorts	1	user	<p>Number of downstream facing ports this Hub supports. See Section 11.23.2.1 of the USB Specification for additional details regarding the use of this field.</p> <p>The value reported is implementation dependent, and is derived from the value defined during Internal Default, or serial port load. The PORT_DIS_SP field defines the ports that are permanently disabled when in Self-Powered operation, and the PORT_DIS_BP field defines the ports that are permanently disabled when in Bus-Powered operation.</p> <p>Internal logic will subtract the number of ports which are disabled, from the total number available (which is 3), and will report the remainder as the number of ports supported. The value reported to the host must coincide with the current operating mode, and will be determined by the following rules.</p> <p>The field used to determine the value that is reported to the host will be:</p> <p>'PORT_DIS_BP' if SELF_BUS_PWR = '0' 'PORT_DIS_SP' if SELF_BUS_PWR = '1'</p>

USB3503

Table 7.11 Class-Specific Hub Descriptor (continued)

OFFSET	FIELD	SIZE	VALUE	DESCRIPTION
3	HubCharacteristics	2	user	<p>Defines support for Logical power switching mode, Compound Device support, Over-current protection, TT Think Time, and Port Indicator support, See Section 11.23.2.1 in the USB Specification for additional details regarding the use of this field.</p> <p>The values delivered to a host are all derived from values defined during Internal Default, or serial port load, and are assigned as follows:</p> <p>D1:0 = '00'b if PORT_PWR = '0' D1:0 = '01'b if PORT_PWR = '1'</p> <p>D2 = 'COMPOUND'</p> <p>D4:3 = 'CURRENT_SNS'</p> <p>D6:5 = '00'b for 8FS (max) bit times of TT think time.</p> <p>D7 = hardcoded to '0' (no Port Indicator Support)</p> <p>D15:8 = '00000000'b</p>
5	PwrOn2PwrGood	1	user	<p>Time (in 2 ms intervals) from the time the power-on sequence begins on a port until power is good on that port. See Section 11.23.2.1 in the USB Specification.</p> <p>The value contained in the 'POWER_ON_TIME' field is directly reported to the host, and is determined by Internal Default, or serial port load.</p>

Table 7.11 Class-Specific Hub Descriptor (continued)

OFFSET	FIELD	SIZE	VALUE	DESCRIPTION
6	HubContrCurrent	1	user	<p>Maximum current requirements of the Hub Controller electronics in 1 mA increments. See Section 11.23.2.1 in the USB Specification for additional details on the use of this field.</p> <p>This field reports the maximum current that only the hub consumes from upstream VBUS when fully operational. This value includes all support circuitry associated with the hub (but does not include the current consumption of any permanently attached peripherals if the hub is part of a compound device).</p> <p>The Hub supports Self-Powered and Bus-Powered operation. The SELF_BUS_PWR bit (CONFIG_BYTE_1) defined in Section 5.3.7, "Register 06h: CONFIG_BYTE_1 - CFG1," on page 29 is used to determine which of the stored values are reported. The value reported to the host must coincide with the current operating mode, and will be determined by the following rules.</p> <p>The value that is reported to the host will be:</p> <p>'HC_MAX_C_BP' if SELF_BUS_PWR = '0' 'HC_MAX_C_SP' if SELF_BUS_PWR = '1'</p> <p>'HC_MAX_C_BP/SP' are defined in Section 5.3.15, and Section 5.3.16, "Register 0Fh: Hub Controller Max Current For Bus Powered Operation - HCMCB," on page 33. In all cases the reported value is sourced from the Hub Controller Max Current data field (for Self or Bus power) that was determined by Internal Default, or serial port load.</p>
7	DeviceRemovable	1	user	<p>Indicates if port has a removable device attached. See Section 11.23.2.1 in the USB Specification.</p> <p>The value contained in the 'NR_DEVICE' field is directly reported to the host, and is determined by Internal Default, or serial port load.</p>
8	PortPwrCtrlMask	1	FFh	Field for backwards USB 1.0 compatibility.

USB3503

7.5 String Descriptors

The USB3503 supports a 30 Character Manufacturer String Descriptor, a 30 Character Product String and a 30 character Serial String.

7.5.1 String Descriptor Zero (specifies languages supported)

Table 7.12 String Descriptor Zero

OFFSET	FIELD	SIZE	VALUE	DESCRIPTION
0	Length	1	04h	Size of this Descriptor.
1	DescriptorType	1	03h	String Descriptor Type.
2	LANGID	2	xxxxh	Language ID code from LANG_ID_H and LANG_ID_L registers

7.5.2 String Descriptor 1 (Manufacturer String)

Table 7.13 String Descriptor 1, Manufacturer String

OFFSET	FIELD	SIZE	VALUE	DESCRIPTION
0	Length	1	yyh	Size of this Descriptor. The yy value is created by taking the MFR_STR_LEN{bytes} + 2{bytes}
1	DescriptorType	1	03h	String Descriptor Type.
2	String	N	string	Manufacturer String The string is located in the MFR_STR register and the size (N) is held in the MFR_STR_LEN register

7.5.3 String Descriptor 2 (Product String)

Table 7.14 String Descriptor 2, Product String

OFFSET	FIELD	SIZE	VALUE	DESCRIPTION
0	Length	1	yyh	Size of this Descriptor. The yy value is created by taking the PRD_STR_LEN{bytes} + 2{bytes}
1	DescriptorType	1	03h	String Descriptor Type.
2	String	N	string	Product String The string is located in the PROD_STR register and the size (N) is held in the PRD_STR_LEN register

7.5.4 String Descriptor 3 (Serial String)

Table 7.15 String Descriptor 3, Serial String

OFFSET	FIELD	SIZE	VALUE	DESCRIPTION
0	Length	1	yyh	Size of this Descriptor. The yy value is created by taking the SER_STR_LEN{bytes} + 2{bytes}

Table 7.15 String Descriptor 3, Serial String

OFFSET	FIELD	SIZE	VALUE	DESCRIPTION
1	DescriptorType	1	03h	String Descriptor Type.
2	String	N	string	Serial String The string is located in the SER_STR register and the size (N) is held in the SER_STR_LEN register

USB3503

Chapter 8 Battery Charging

In order to detect the charger, the device applies and monitors voltages on the USBUP_DP and USBUP_DM pins. If a voltage within the specified range is detected, the Charger Detection Register in the I²C register space shall be updated to reflect the proper status.

8.1 Downstream Port Battery Charging Support

The USB3503 can configure any of the downstream ports to support battery charger handshake.

The Hub's role in downstream battery charging is to provide an acknowledge to a device's query as to if the hub *system* supports USB battery charging. The hub *silicon* does not provide any current or power FETs or any such thing to actually charge the device. Those components would need to be provided as external components in the final Hub board design.

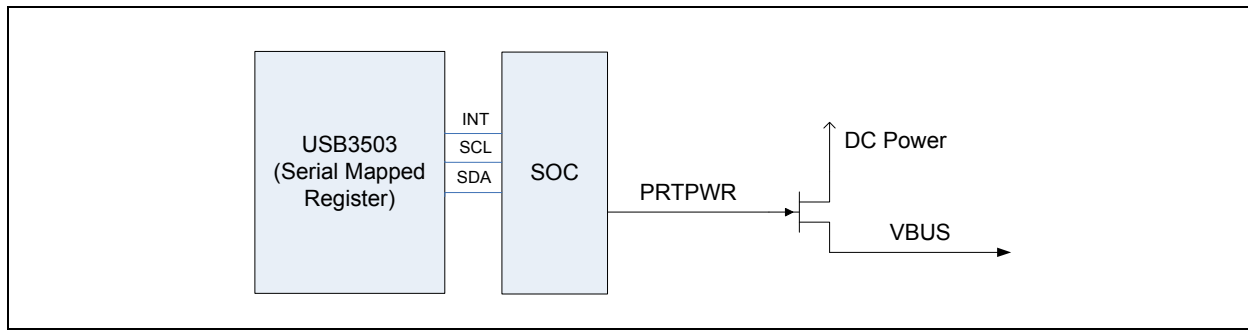

Figure 8.1 Battery Charging External Power Supply

If the final Hub board design provides an external supply capable of supplying current per the battery charging specification, the hub can be configured to indicate the presence of such a supply to the device. This indication is on a per/port basis. i.e. the board can configure two ports to support battery charging (thru high current power FET's) and leave the other port as a standard USB port.

8.1.1 USB Battery Charging

In the terminology of the USB battery charging specification, if the port is configured to support battery charging, the downstream port is a "Charging Host Port". All AC/DC characteristics will comply with only this type. If the port is not configured to support battery charging, the port is a "Standard Host Port". AC/DC characteristics comply with the USB 2.0 specification.

A downstream port will only behave as a "Charging Host Port" or a "Standard Host Port". The port will not switch between "Charging Host Port" or Standard Host Port" at any time after initial power-up and configuration.

8.1.2 Special Behavior of P RTPWR Register

The USB Battery charging specification does not address system issues. It only defines a low level protocol for a device and host (or hub) to communicate a simple question and optional answer.

Device queries if the host to which it is connected supports battery charging.

The host will respond that it does support battery charging or does not respond at all. There is no negative response. (A lack of response is taken as a negative response)

When ports are configured for downstream battery charging, the corresponding P RTPWR setting will be controlled by downstream battery charging logic instead of the normal hub logic.

PRTPOWER setting will assert after initial hub customer configuration (Internal default/Serial register writes). PRTPOWER will remain asserted and under the control of the battery charge logic until one of two events.

1. An overcurrent is detected on the corresponding OCS_N pin. In this case, PRTPOWER setting will negate. The only way to re-enable the PRTPOWER setting from this state is to RESET the USB3503.
2. The hub enters Hub.Communication stage, connects on its upstream port and is enumerated by a USB host. In this case, control over the PRTPOWER setting reverts back to the hub logic inside the USB3503 and the normal USB behavior applies. In this case, the host must enable PRTPOWER.

Since the enumeration process for a hub sets the PORT_POWER feature for all downstream ports, this information can be used to switch control over the PRTPOWER setting between the battery charge logic and the hub logic.

- When the Hub PORT_POWER feature is '1', the hub logic controls the PRTPOWER setting.
- When the Hub PORT_POWER feature is '0', the battery charging logic controls the PRTPOWER setting.

No matter which controller is controlling the PRTPOWER setting, an overcurrent event will always negate PRTPOWER setting.

8.1.3 Battery Charging Configuration

Configuration of ports to support battery charging is done through serial port configuration load.

[Register D0: Downstream Battery Charging Enable - BC_EN](#) is allocated for Battery Charging support. The register, starting from Bit 1, enables Battery charging for each downstream port when asserted. Bit 1 represents port 1 and so on. Each port with battery charging enabled asserts the corresponding PRTPOWER register bit.

USB3503

Chapter 9 Integrated Power Regulators

9.1 Overview

The integrated power regulators are designed to provide significant flexibility to the system in providing power to the USB3503. Several different configurations are allowed in order to align the USB3503 power structure to the supplies available in the system.

9.1.1 3.3V Regulator

The USB3503 has an integrated regulator to convert from VBAT to 3.3V.

9.1.2 1.2V Regulator

The USB3503 has an integrated regulator to convert from a variable voltage input on VDD_CORE_REG to 1.2V. The 1.2V regulator shall be tolerant to the presence of low voltage (~0V) on the VDD_CORE_REG pin in order to support system power solutions where a 1.8V supply is not always present in low power states.

The 1.2V regulator shall support an input voltage range consistent with a 1.8V input in order to reduce power consumption in systems which provide multiple power supply levels. In addition the 1.2V regulator shall support an input voltage up to 3.3V for systems which provide only a single power supply. The device will support operation where the 3.3V regulator output can drive the 1.2V regulator input such that VBAT is the only required supply.

9.2 Power Configurations

The USB3503 support operation with no back current when power is connected in each of the following configurations.

9.2.1 Single Supply Configurations

9.2.1.1 VBAT Only

VBAT should be tied to the VBAT system supply. VDD33_BYP regulator output and VDD_CORE_REG should be tied together on the board. In this configuration the 3.3V regulator will be active, and the 3.3V to 1.2V regulator will be active.

9.2.1.2 3.3V Only

VBAT should be tied to the 3.3V system supply. VDD33_BYP and VDD_CORE_REG pins should be tied together on the board. In this configuration, the 3.3V regulator will operate in dropout. The 1.2V regulator will be active.

9.2.2 Double Supply Configurations

9.2.2.1 VBAT + 1.8V

VBAT should be tied to the VBAT system supply. VDD33_BYP regulator output requires external capacitor. VDD_CORE_REG should be tied to the 1.8V system supply. In this configuration, the 3.3V regulator and the 1.2V regulator will be active.

9.2.2.2 3.3V + 1.8V

VBAT should be tied to the 3.3V system supply. VDD33_BYP should be connected to the 3.3V external capacitor. VDD_CORE_REG should be tied to the 1.8v system supply. In this configuration the 3.3V regulator will operate in dropout. The 1.2V regulator will be active.

9.3 Regulator Control Signals

The regulators are controlled by **RESET_N**. When **RESET_N** is brought high the VDD33 regulator will turn on. When **RESET_N** is brought low the VDD33 regulator will turn off.

USB3503

Chapter 10 Specifications

10.1 Absolute Maximum Ratings

Table 10.1 Absolute Maximum Ratings

PARAMETER	SYMBOL	CONDITIONS	MIN	MAX	UNITS
VBAT	V _{BAT}		-0.5	5.5	V
VDD_CORE_REG	V _{DD_CORE_REG}		-0.5	4.6	V
VDD33	V _{DD33_BYP}		-0.5	4.6	V
Maximum IO Voltage to Ground	V _{IO}		-0.5	4.6	V
REFCLK Voltage	V _{MAX_REFCLK}		-0.5	3.6	V
Voltage on USB+ and USB- pins	V _{MAX_USB}		-0.5	5.5	V
Operating Temperature	T _{MAX_OP}	Commercial	0	70	C
Operating Temperature	T _{MAX_OP}	Industrial	-40	85	C
Storage Temperature	T _{MAX_STG}		-55	150	C

Note: Stresses beyond those listed under “Absolute Maximum Ratings” may cause permanent damage to the device. Exposure to absolute maximum rating conditions for extended periods may affect device reliability.

Note: This is a stress rating only and functional operation of the device at any other condition above those indicated in the operation sections of this specification is not implied.

Note: When powering this device from laboratory or system power supplies, it is important that the Absolute Maximum Ratings not be exceeded or device failure can result. Some power supplies exhibit voltage spikes on their outputs when the AC power is switched on or off. In addition, voltage transients on the AC power line may appear on the DC output. When this possibility exists, it is suggested that a clamp circuit be used.

10.2 Recommended Operating Conditions

Table 10.2 Recommended Operating Conditions

PARAMETER	SYMBOL	CONDITIONS	MIN	TYP	MAX	UNITS
VBAT	V _{BAT}		2.9		5.5	V
VDD_CORE_REG	V _{DD_CORE_REG}	Note 10.1	1.6	1.8	2.0	V
VDD_CORE_REG	V _{DD_CORE_REG}	Note 10.2	3.0	3.3	3.6	V
Input Voltage (DP, DM)	V _{IUSB}		-0.3		5.5	V
Input Voltage (STROBE, DATA)	V _{IHSIC}		-0.3	1.2	1.32	V
Input Voltage on I/O Pins	V _I		-0.3	1.8	3.6	V

Table 10.2 Recommended Operating Conditions (continued)

PARAMETER	SYMBOL	CONDITIONS	MIN	TYP	MAX	UNITS
Voltage on REFCLK	V _{REFCLK}		-0.3		3.6	V
Ambient Temperature	T _A	Commercial	0		70	C
Ambient Temperature	T _A	Industrial	-40		85	C

Note 10.1 Applicable only when VDD_CORE_REG is supplied from external power supply.

Note 10.2 Applicable only when VDD_CORE_REG is tied to VDD33_BYP.

10.3 Operating Current

The following conditions are assumed unless otherwise specified:

V_{BAT} = 3.0 to 5.5V; V_{DD_CORE} = 1.6 to 2.0V; V_{SS} = 0V;

T_A = 0C to +70C (Commercial), -40C to +85C (Industrial)

Table 10.3 Operating Current (Dual Supply)

PARAMETER	SYMBOL	CONDITIONS	MIN	TYP	MAX	UNITS
High Speed USB Operation with Upstream HSIC	I _{BAT(HS)}	Active USB Transfer RESET_N = 1 3 Downstream Ports Active	55	65	68	mA
	I _{CORE(HS)}		29	33	38	mA
High Speed USB Operation with Upstream HSIC	I _{BAT(HS)}	Active USB Transfer RESET_N = 1 2 Downstream Ports Active, 1 Port Disabled	33	43	45	mA
	I _{CORE(HS)}		26	28	35	mA
High Speed USB Operation with Upstream HSIC	I _{BAT(HS)}	Active USB Transfer RESET_N = 1 1 Downstream Port Active, 2 Ports Disabled	19	23	25	mA
	I _{CORE(HS)}		22	24	30	mA
High Speed USB Operation with Upstream HSIC	I _{BAT(HS)}	High Speed Idle RESET_N = 1 3 Downstream Ports Enabled, No USB Data Transfer	20	21	23	mA
	I _{CORE(HS)}		24	25	29	mA
High Speed USB Operation with Upstream HSIC	I _{BAT(HS)}	High Speed Idle RESET_N = 1 1 Downstream Port Enabled, No USB Data Transfer	12	13	14	mA
	I _{CORE(HS)}		19	20	23	mA
Unconfigured (High Speed)	I _{BAT(UNCONF)}	RESET_N = 1	7	8	10	mA
	I _{CORE(UNCONF)}		17	18	22	mA
STANDBY Mode	I _{BAT(STDBY)}	RESET_N = 0 Commercial Temp	0	0.4	2.5	μA
	I _{CORE(STDBY)}		0	0	0.5	μA

USB3503

Table 10.3 Operating Current (Dual Supply) (continued)

PARAMETER	SYMBOL	CONDITIONS	MIN	TYP	MAX	UNITS
STANDBY Mode	I _{VBAT(STDBY)}	RESET_N = 0 Industrial Temp	0	0.6	3.9	μA
	I _{CORE(STDBY)}		0	0	0.9	μA
SUSPEND Mode	I _{VBAT(SPND)}	USB Suspend Commercial Temp	65	73	110	μA
	I _{CORE(SPND)}		125	165	765	μA
SUSPEND Mode	I _{VBAT(SPND)}	USB Suspend Industrial Temp	65	73	125	μA
	I _{CORE(SPND)}		125	165	1050	μA

The following conditions are assumed unless otherwise specified:

V_{BAT} = 3.0 to 5.5V; V_{SS} = 0V; T_A = 0C to +70C (Commercial), -40C to +85C (Industrial)

Table 10.4 Operating Current (Single Supply)

PARAMETER	SYMBOL	CONDITIONS	MIN	TYP	MAX	UNITS
High Speed USB Operation with Upstream HSIC	I _{VBAT(HS)}	Active USB Transfer RESET_N = 1 3 Downstream Ports Active	88	98	110	mA
High Speed USB Operation with Upstream HSIC	I _{VBAT(HS)}	Active USB Transfer RESET_N = 1 2 Downstream Ports Active, 1 Port Disabled	69	72	80	mA
High Speed USB Operation with Upstream HSIC	I _{VBAT(HS)}	Active USB Transfer RESET_N = 1 1 Downstream Port Active, 2 Ports Disabled	45	48	55	mA
High Speed USB Operation with Upstream HSIC	I _{VBAT(HS)}	High Speed Idle RESET_N = 1 3 Downstream Ports Enabled, No USB Data Transfer	47	50	53	mA
High Speed USB Operation with Upstream HSIC	I _{VBAT(HS)}	High Speed Idle RESET_N = 1 1 Downstream Port Enabled, No USB Data Transfer	34	35	36	mA
Unconfigured (High Speed)	I _{VBAT(UNCONF)}	RESET_N = 1	28	29	30	mA
STANDBY Mode	I _{VBAT(STDBY)}	RESET_N = 0 Commercial Temp	0	0.6	2.6	μA
STANDBY Mode	I _{VBAT(STDBY)}	RESET_N = 0 Industrial Temp	0	0.6	3.1	μA
SUSPEND Mode	I _{VBAT(SPND)}	USB Suspend Commercial Temp	215	250	925	μA

Table 10.4 Operating Current (Single Supply) (continued)

PARAMETER	SYMBOL	CONDITIONS	MIN	TYP	MAX	UNITS
SUSPEND Mode	$I_{VBAT(SPND)}$	USB Suspend Industrial Temp	215	250	1330	μA

10.4 DC Characteristics: Digital I/O Pins

Note: $T_A = -40^\circ\text{C}$ to 85°C

Table 10.5 Digital I/O Characteristics

PARAMETER	SYMBOL	CONDITIONS	MIN	TYP	MAX	UNITS
Low-Level Input Voltage	V_{IL}	Note 10.3	-0.3		0.42	V
Low-Level Input Voltage	V_{IL}	Note 10.4	-0.3		0.34	V
High-Level Input Voltage	V_{IH}		1.25		$V_{DD33_BYP} + 0.3V$	V
Low-Level Input Voltage RESET	V_{IL_RST}		-0.3		0.38	V
High-Level Input Voltage RESET	V_{IH_RST}		1.0		$V_{DD33_BYP} + 0.3V$	V
Low-Level Input Voltage OSC	V_{IL_OSC}		-0.3		0.55	V
High-Level Input Voltage OSC	V_{IH_OSC}		0.8		$V_{DD33_BYP} + 0.3V$	V
Low-Level Input Voltage REFCLK	V_{IL_REF}		-0.3		0.5	V
High-Level Input Voltage REFCLK	V_{IH_REF}		1.4		$V_{DD33_BYP} + 0.3V$	V
Clock Input Capacitance REFCLK	C_{IN}				2	pF
Low-Level Output Voltage	V_{OL}	@ $I_{OL}=12\text{mA}$ sink current			0.4	V
Pin Capacitance	C_{pin}			2	20	pF
Output Current Capability	I_O		12	20	24	mA

Note 10.3 For I2C interface using pullups to less than 2.1V.

Note 10.4 For I2C interface using pullups to greater than 2.1V.

10.5 DC Characteristics: Analog I/O Pins

Table 10.6 DC Characteristics: Analog I/O Pins (DP/DM)

PARAMETER	SYMBOL	CONDITIONS	MIN	TYP	MAX	UNITS
LS/FS FUNCTIONALITY						

USB3503

Table 10.6 DC Characteristics: Analog I/O Pins (DP/DM) (continued)

PARAMETER	SYMBOL	CONDITIONS	MIN	TYP	MAX	UNITS
Input levels						
Differential Receiver Input Sensitivity	V_{DIFS}	$ V(DP) - V(DM) $	0.2			V
Differential Receiver Common-Mode Voltage	V_{CMFS}		0.8		2.5	V
Single-Ended Receiver Low Level Input Voltage	V_{ILSE}				0.8	V
Single-Ended Receiver High Level Input Voltage	V_{IHSE}		2.0			V
Single-Ended Receiver Hysteresis	V_{HYSSE}		0.050		0.150	V
Output Levels						
Low Level Output Voltage	V_{FSOL}	Pull-up resistor on DP; $R_L = 1.5k\Omega$ to V_{DD33_BYP}			0.3	V
High Level Output Voltage	V_{FSOH}	Pull-down resistor on DP, DM; $R_L = 15k\Omega$ to GND	2.8		3.6	V
Termination						
Driver Output Impedance for HS	Z_{HSDRV}	Steady state drive	40.5	45	49.5	Ω
Input Impedance	Z_{INP}	RX, RPU, RPD disabled	1.0			M Ω
Pull-dn Resistor Impedance	R_{PD}	Note 10.5	14.25	16.9	20	k Ω
HS FUNCTIONALITY						
Input levels						
HS Differential Input Sensitivity	V_{DIHS}	$ V(DP) - V(DM) $	100			mV
HS Data Signaling Common Mode Voltage Range	V_{CMHS}		-50		500	mV
HS Squelch Detection Threshold (Differential)	V_{HSSQ}		100		150	mV
HS Disconnect Threshold	V_{HSDSC}		525		625	mV
Output Levels						
High Speed Low Level Output Voltage (DP/DM referenced to GND)	V_{HSOL}	45 Ω load	-10		10	mV
High Speed High Level Output Voltage (DP/DM referenced to GND)	V_{HSOH}	45 Ω load	360		440	mV
High Speed IDLE Level Output Voltage (DP/DM referenced to GND)	V_{OLHS}	45 Ω load	-10		10	mV

Table 10.6 DC Characteristics: Analog I/O Pins (DP/DM) (continued)

PARAMETER	SYMBOL	CONDITIONS	MIN	TYP	MAX	UNITS
Leakage Current						
OFF-State Leakage Current	I_{LZ}				±10	μA
Port Capacitance						
Transceiver Input Capacitance	C_{IN}	Pin to GND		5	10	pF

Note 10.5 The resistor value follows the 27% Resistor ECN published by the USB-IF.

10.6 Dynamic Characteristics: Digital I/O Pins

Table 10.7 Dynamic Characteristics: Digital I/O Pins (RESET_N)

PARAMETER	SYMBOL	CONDITIONS	MIN	TYP	MAX	UNITS
Minimum Active Low Pulse on RESET_N	T_{RESET}	RESET_N = '0'	100			μs

10.7 Dynamic Characteristics: Analog I/O Pins

Table 10.8 Dynamic Characteristics: Analog I/O Pins (DP/DM)

PARAMETER	SYMBOL	CONDITIONS	MIN	TYP	MAX	UNITS
FS Output Driver Timing						
FS Rise Time	T_{FR}	$C_L = 50\text{pF}$; 10 to 90% of $ V_{OH} - V_{OL} $	4		20	ns
FS Fall Time	T_{FF}	$C_L = 50\text{pF}$; 10 to 90% of $ V_{OH} - V_{OL} $	4		20	ns
Output Signal Crossover Voltage	V_{CRS}	Excluding the first transition from IDLE state	1.3		2.0	V
Differential Rise/Fall Time Matching	T_{FRFM}	Excluding the first transition from IDLE state	90		111.1	%
LS Output Driver Timing						
LS Rise Time	T_{LR}	$C_L = 50\text{-}600\text{pF}$; 10 to 90% of $ V_{OH} - V_{OL} $	75		300	ns
LS Fall Time	T_{LF}	$C_L = 50\text{-}600\text{pF}$; 10 to 90% of $ V_{OH} - V_{OL} $	75		300	ns
Differential Rise/Fall Time Matching	T_{LRFM}	Excluding the first transition from IDLE state	80		125	%
HS Output Driver Timing						
Differential Rise Time	T_{HSR}		500			ps
Differential Fall Time	T_{HSF}		500			ps

USB3503

Table 10.8 Dynamic Characteristics: Analog I/O Pins (DP/DM) (continued)

PARAMETER	SYMBOL	CONDITIONS	MIN	TYP	MAX	UNITS
Driver Waveform Requirements		Eye pattern of Template 1 in USB 2.0 specification				
High Speed Mode Timing						
Receiver Waveform Requirements		Eye pattern of Template 4 in USB 2.0 specification				
Data Source Jitter and Receiver Jitter Tolerance		Eye pattern of Template 4 in USB 2.0 specification				

10.8 Regulator Output Voltages and Capacitor Requirement

Table 10.9 Regulator Output Voltages and Capacitor Requirement

PARAMETER	SYMBOL	CONDITIONS	MIN	TYP	MAX	UNITS
Regulator Output Voltage	V _{DD33}	5.5V > V _{BAT} > 2.9V	2.8	3.3	3.6	V
Regulator Capacitor	C _{BYP33}		4.7			μF
Capacitor ESR	C _{ESR33}				1	Ω
Regulator Output Voltage	V _{DD12}	3.6V > V _{DD33} > 2.8V	1.1	1.2	1.3	V
Regulator Capacitor	C _{BYP12}		1.0			μF
Capacitor ESR	C _{ESR12}				1	Ω

10.9 ESD and Latch-Up Performance

Table 10.10 ESD and Latch-up Performance

PARAMETER	CONDITIONS	MIN	TYP	MAX	UNITS	COMMENTS
ESD PERFORMANCE						
	Human Body Model			±5	kV	Device
System	EN/IEC 61000-4-2 Contact Discharge			±15	kV	3rd party system test
System	EN/IEC 61000-4-2 Air-gap Discharge			±15	kV	3rd party system test
LATCH-UP PERFORMANCE						
All Pins	EIA/JESD 78, Class II		150		mA	

10.10 ESD Performance

The USB3503 is protected from ESD strikes. By eliminating the requirement for external ESD protection devices, board space is conserved, and the board manufacturer is enabled to reduce cost. The advanced ESD structures integrated into the USB3503 protect the device whether or not it is powered up.

10.10.1 Human Body Model (HBM) Performance

HBM testing verifies the ability to withstand the ESD strikes like those that occur during handling and manufacturing, and is done without power applied to the IC. To pass the test, the device must have no change in operation or performance due to the event. All pins on the USB3503 provide ± 5 kV HBM protection, as shown in [Table 10.10](#).

10.10.2 EN 61000-4-2 Performance

The EN 61000-4-2 ESD specification is an international standard that addresses system-level immunity to ESD strikes while the end equipment is operational. In contrast, the HBM ESD tests are performed at the device level with the device powered down.

Microchip contracts with Independent laboratories to test the USB3503 to EN 61000-4-2 in a working system. Reports are available upon request. Please contact your representative, and request information on 3rd party ESD test results. The reports show that systems designed with the USB3503 can safely provide the ESD performance shown in without additional board level protection.

In addition to defining the ESD tests, EN 61000-4-2 also categorizes the impact to equipment operation when the strike occurs (ESD Result Classification). Both air discharge and contact discharge test techniques for applying stress conditions are defined by the EN 61000-4-2 ESD document.

10.10.3 Air Discharge

To perform this test, a charged electrode is moved close to the system being tested until a spark is generated. This test is difficult to reproduce because the discharge is influenced by such factors as humidity, the speed of approach of the electrode, and construction of the test equipment.

10.10.4 Contact Discharge

The uncharged electrode first contacts the pin to prepare this test, and then the probe tip is energized. This yields more repeatable results, and is the preferred test method. The independent test laboratories contracted by Microchop provide test results for both types of discharge methods.

10.11 AC Specifications

10.11.1 REFCLK

External Clock: 50% duty cycle $\pm 10\%$, ± 350 ppm, Jitter < 100ps rms.

10.11.2 Serial Interface

The Hub conforms to AC specifications as set forth in the I2C Specification for Slave-Only devices.

10.11.3 USB 2.0

The Hub conforms to all voltage, power, and timing characteristics and specifications as set forth in the USB 2.0 Specification. Please refer to the USB 2.0 Specification which is available from the www.usb.org web site.

USB3503

10.11.4 USB 2.0 HSIC

The upstream port of the HSIC Hub conforms to all voltage, power, and timing characteristics and specifications as set forth in the High-Speed Inter-Chip USB Electrical Specification Version 1.0. Please refer to the USB 2.0 HSIC Specification which is available from the www.usb.org web site.

Chapter 11 Application Reference

11.1 Application Diagram

The USB3503 requires several external components to function and insure compliance with the USB 2.0 specification.

Table 11.1 Component Values in Application Diagrams

REFERENCE DESIGNATOR	VALUE	DESCRIPTION	NOTES
C _{VDD12BYP}	1.0 μ F	Capacitor to ground for regulator stability.	Place as close to the USB3503 as possible
C _{VDD33BYP}	4.7 μ F	Capacitor to ground for regulator stability.	Place as close to the USB3503 as possible
C _{OUT}	0.1 μ F	Bypass capacitor to ground.	Place as close to the USB3503 as possible
R _{BIAS}	12.0k	Series resistor to establish reference voltage used by analog circuits.	Place as close to the USB3503 as possible
R _{PU1}	10k or 1k	Pull-up for I2C bus. 10k for 100kHz or 400kHz operation. 1k for 1MHz operation.	
R _{PU2}	10k (or greater)	Pull-up for open-drain outputs	

Table 11.2 Capacitance Values at VBUS of USB Connector

PORT	MIN VALUE	MAX VALUE
Downstream	120 μ F	

USB3503

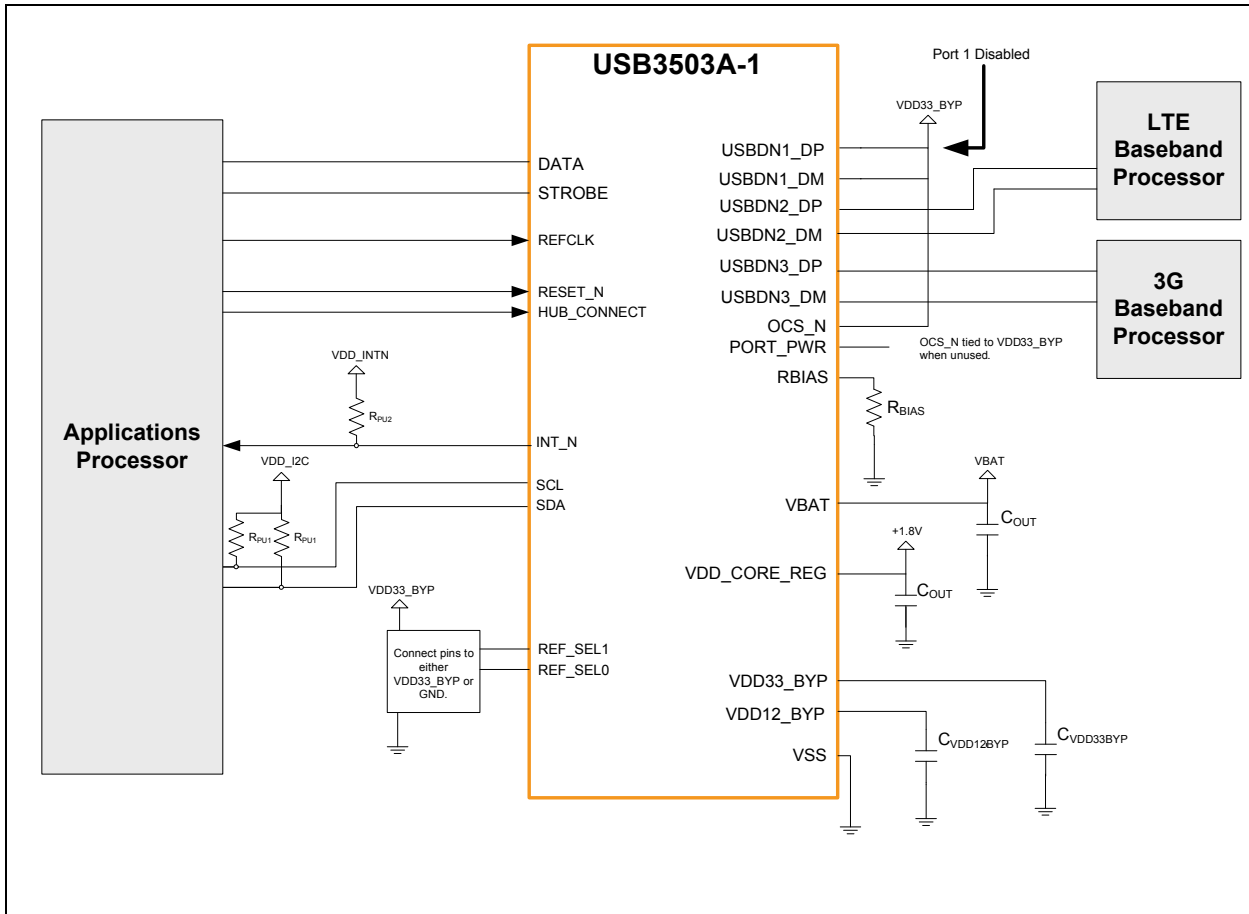

Figure 11.1 Internal Chip-to-Chip Interface

Note: While RESET_N is driven low, all other inputs from Applications Processor should also be driven low in order to minimize current draw.

Note: To disable a downstream port, tie DP and DM to VDD33_BYP pin of the USB3503.

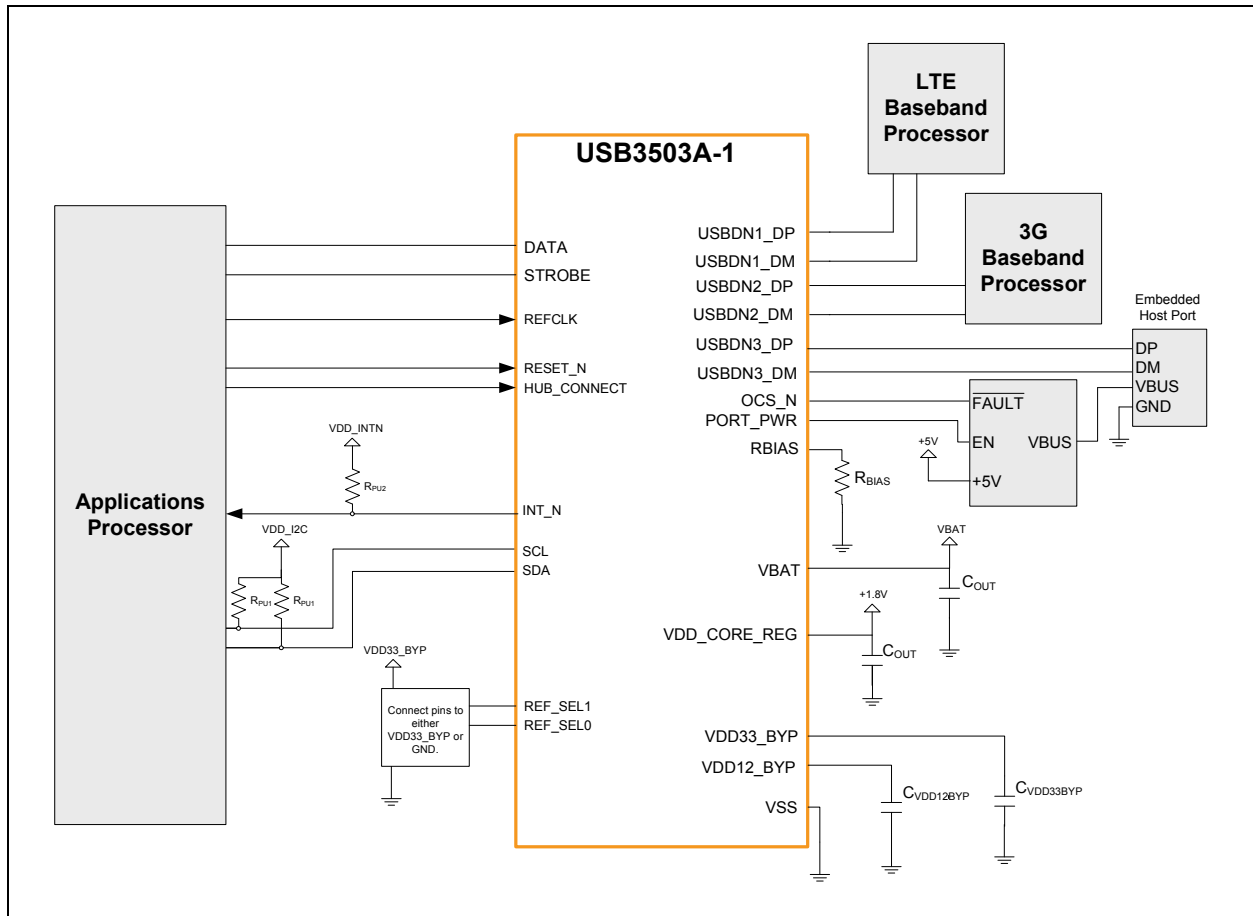

Figure 11.2 Internal Chip-to-Chip Interface with Embedded Host Port

Chapter 12 Package Outlines, Tape & Reel Drawings, Package Marking

12.1 25-Ball WLCSP

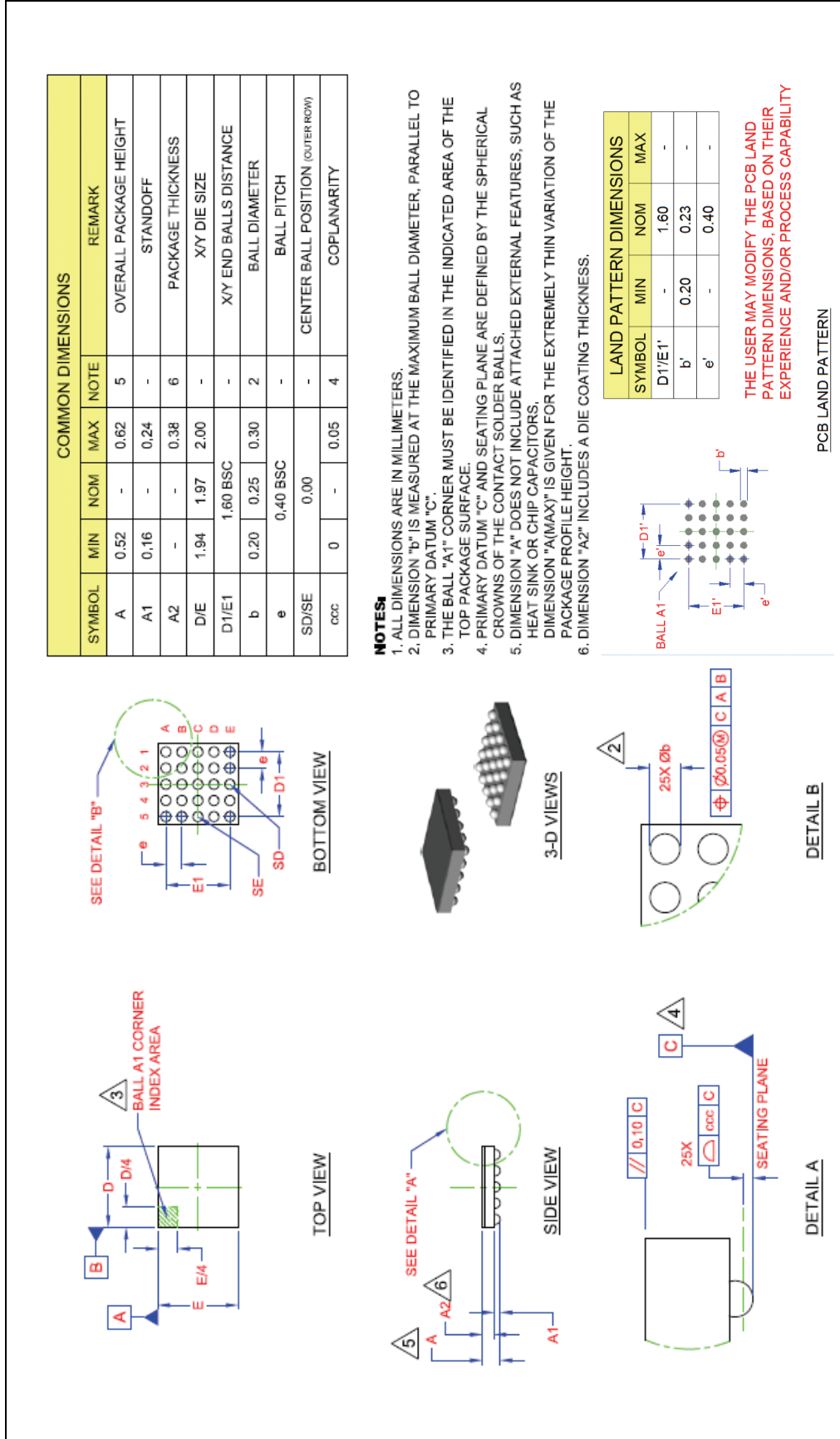

Figure 12.1 25-Ball WLCSP, 1.97x1.97mm Body, 0.4mm Pitch Package Drawing

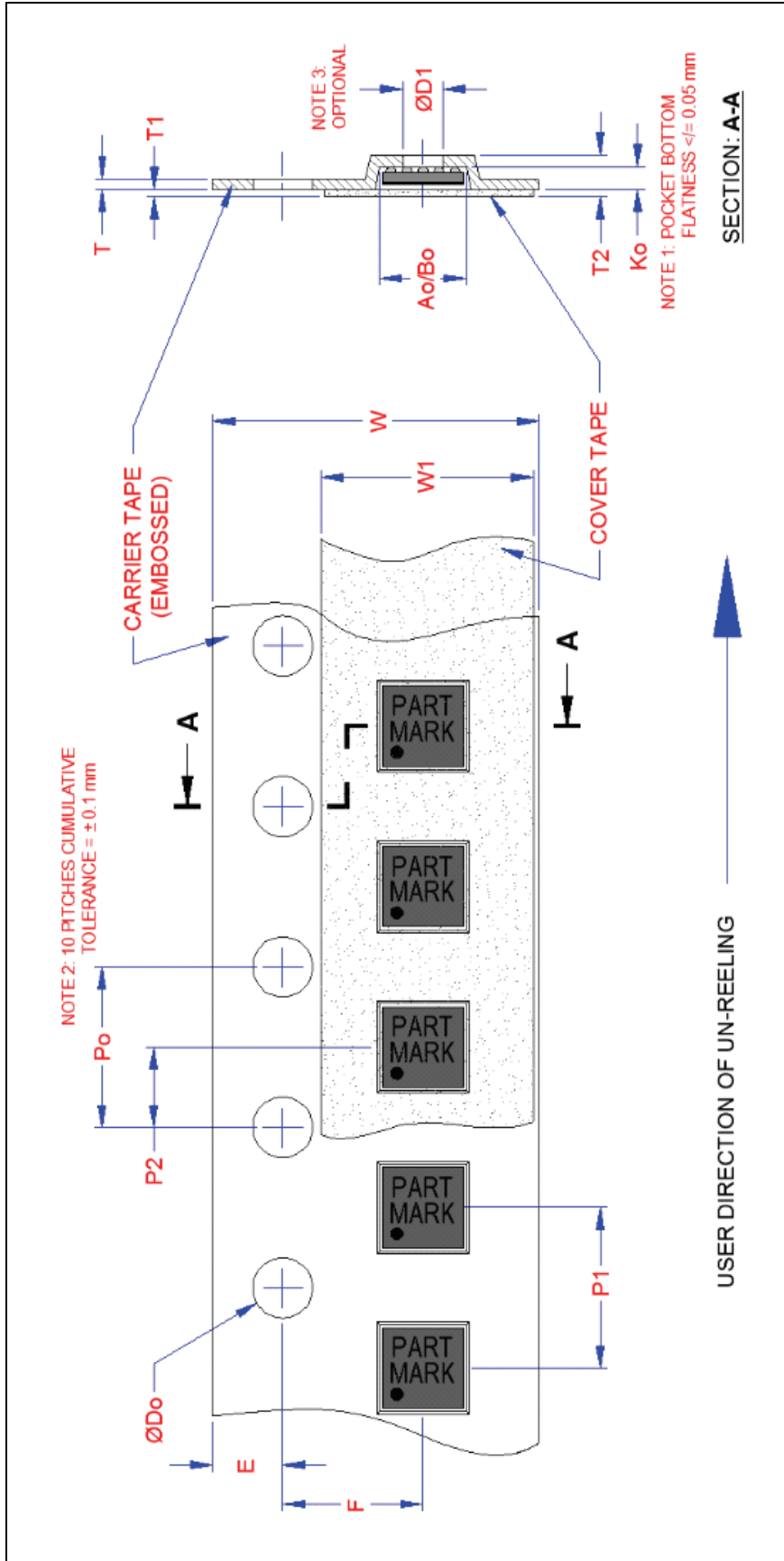

Figure 12.2 25-Ball WLCSP Tape and Reel

USB3503

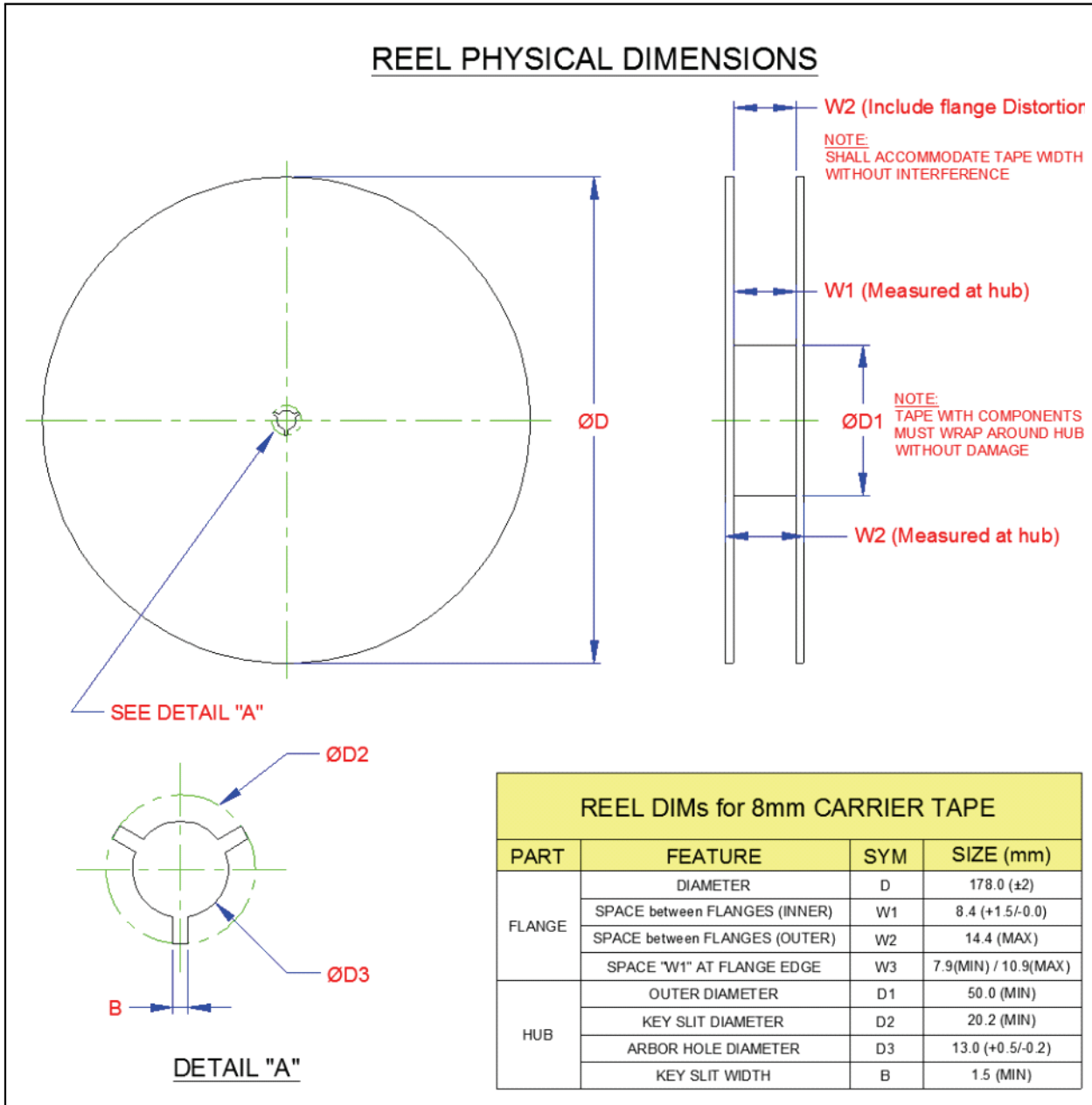

Figure 12.3 25-Ball WLCSP Reel Dimensions

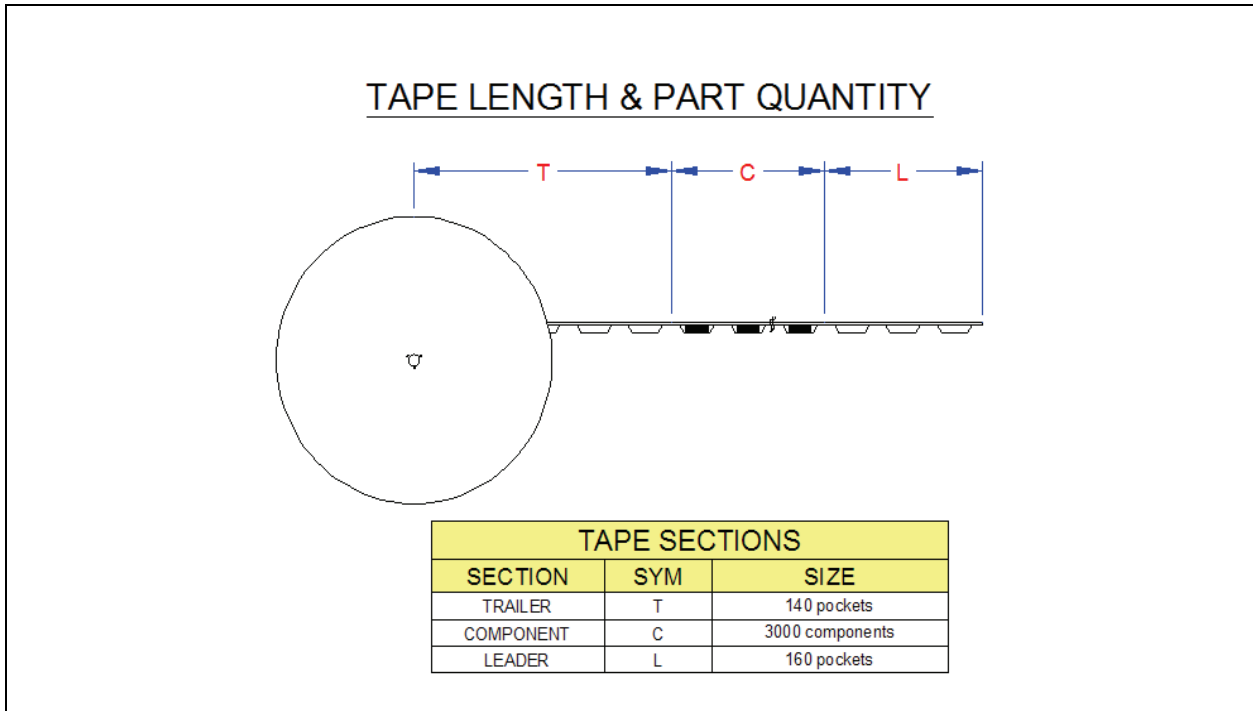

Figure 12.4 25-Ball WLCSP Tape Sections

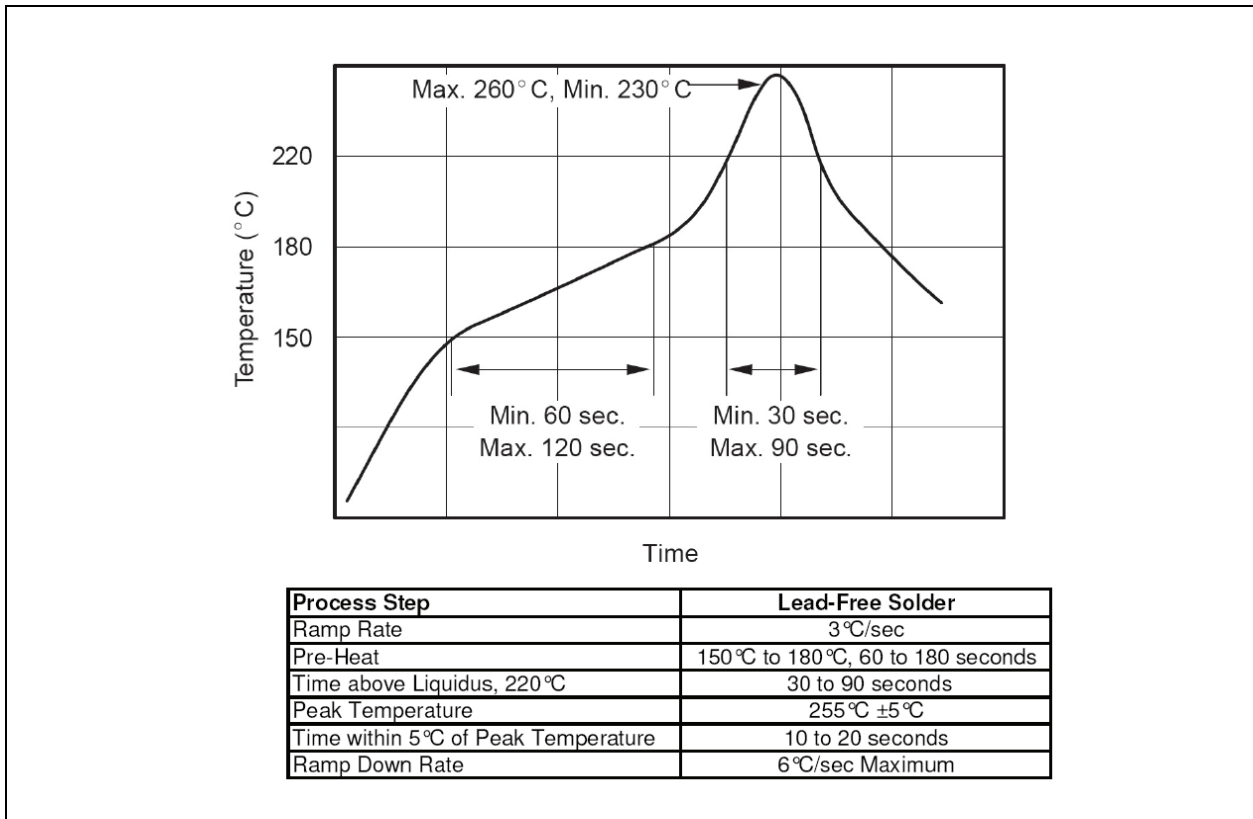

Figure 12.5 25-Ball WLCSP Reflow Profile and Critical Parameters for RoHS Compliant (SnAgCu) Solder

USB3503

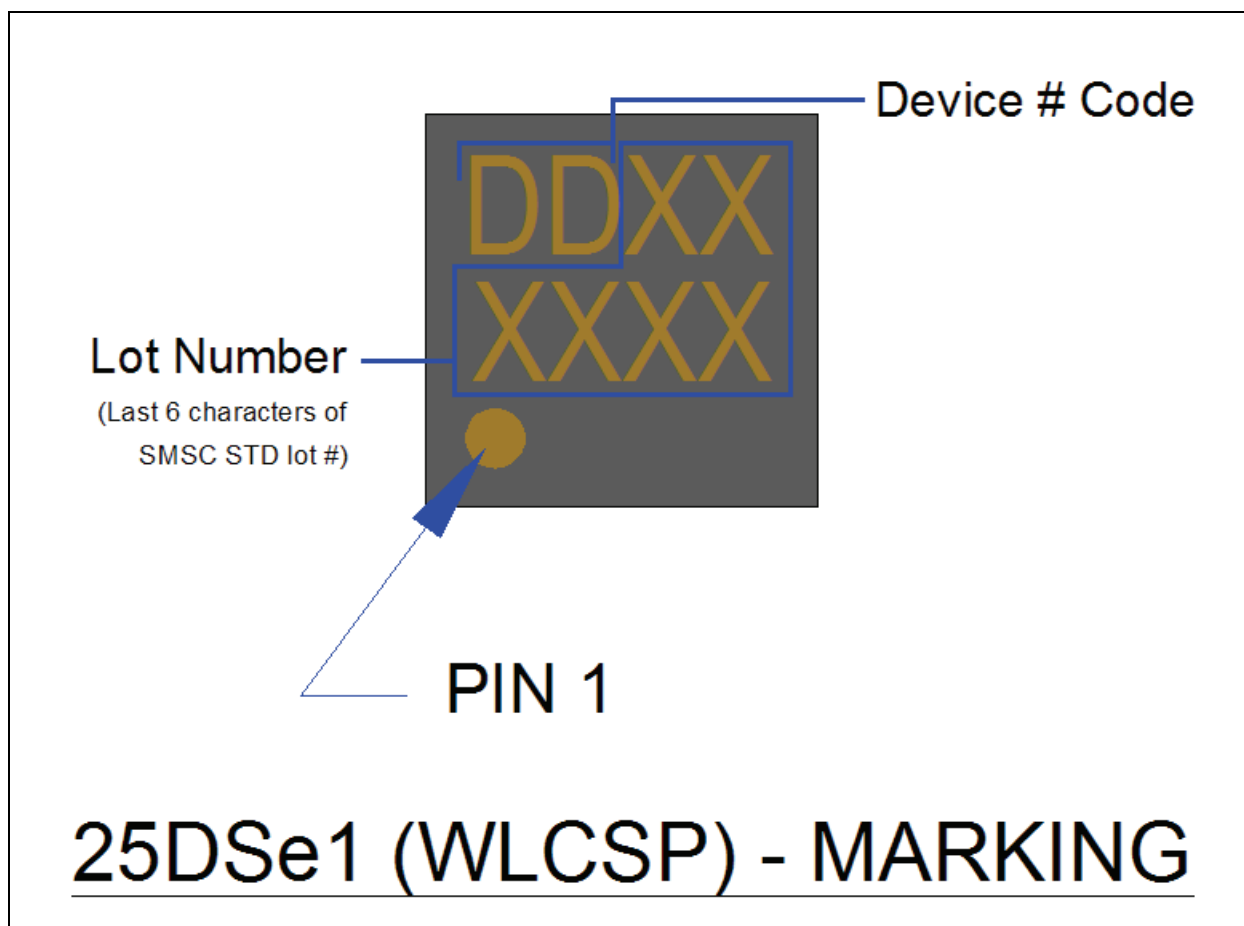

Figure 12.6 25-Ball WLCSP Package Marking

12.2 32-Pin SQFN

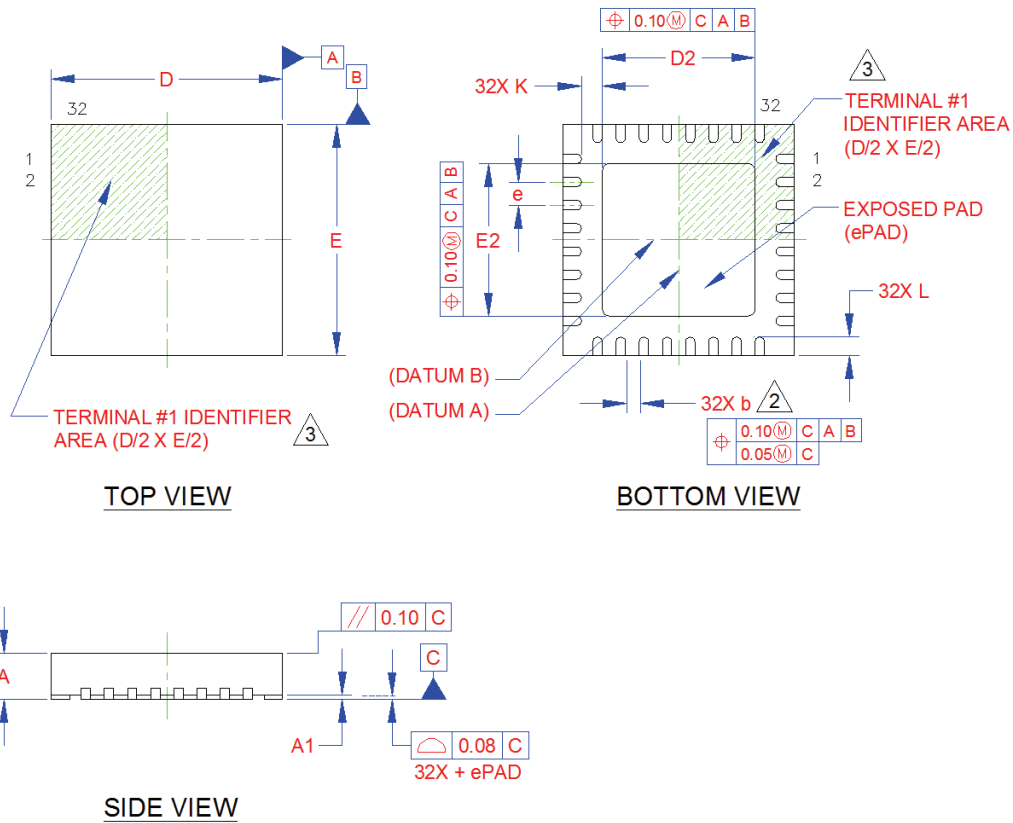

Figure 12.7 32-SQFN Package

Table 12.1 32-SQFN Dimensions

	MIN	NOMINAL	MAX	REMARKS
A	0.80	0.90	1.00	Overall Package Height
A1	0	0.02	0.05	Standoff
D/E	4.90	5.00	5.10	X/Y Body Size
D2/E2	3.20	3.30	3.40	X/Y Exposed Pad Size
L	0.35	0.40	0.45	Terminal Length
b	0.18	0.25	0.30	Terminal Width
k	0.35	0.45	-	Pin to Exposed Pad Clearance
e	0.50 BSC			Terminal Pitch

Notes:

1. All dimensions are in millimeters unless otherwise noted.
2. Dimension "b" applies to plated terminals and is measured between 0.15 and 0.30 mm from the terminal tip.
3. The pin 1 identifier may vary, but is always located within the zone indicated.

USB3503

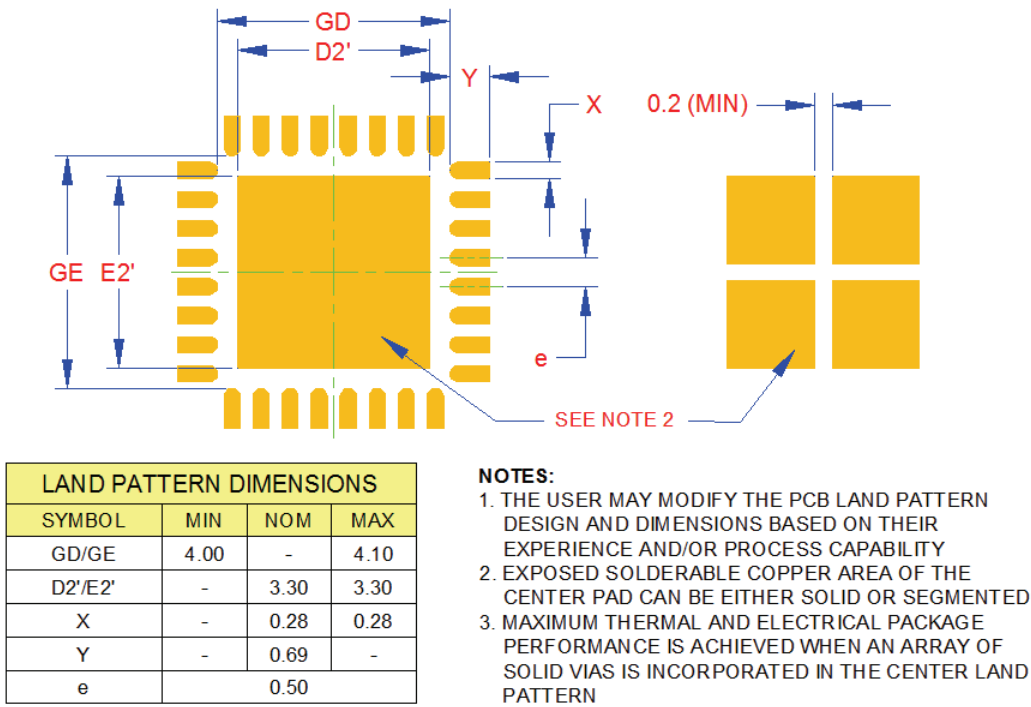

Figure 12.8 Recommended PCB Land Pattern

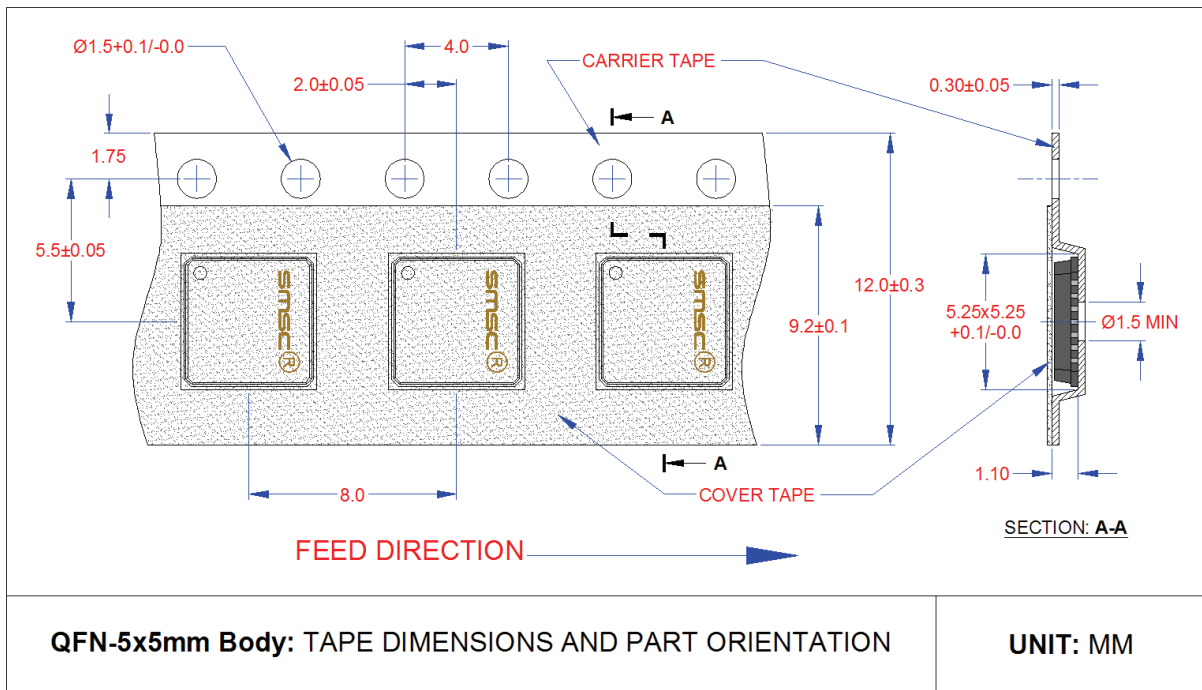

Figure 12.9 Taping Dimensions and Part Orientation

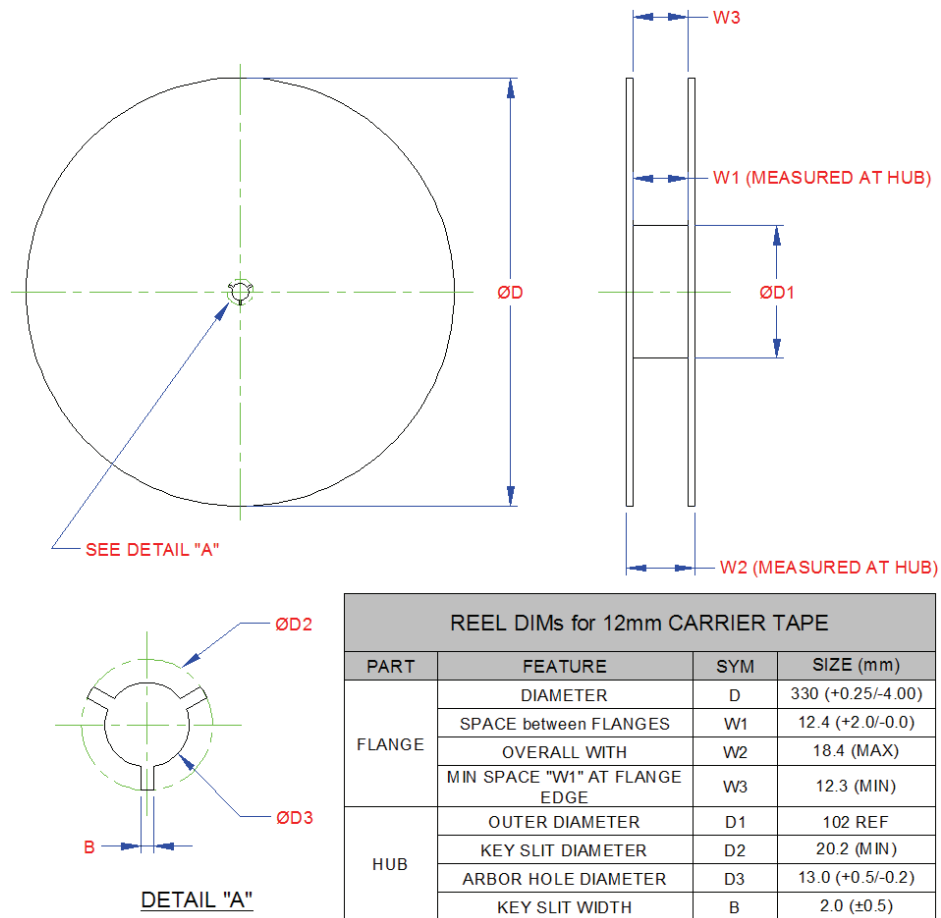

Figure 12.10 Reel Dimensions

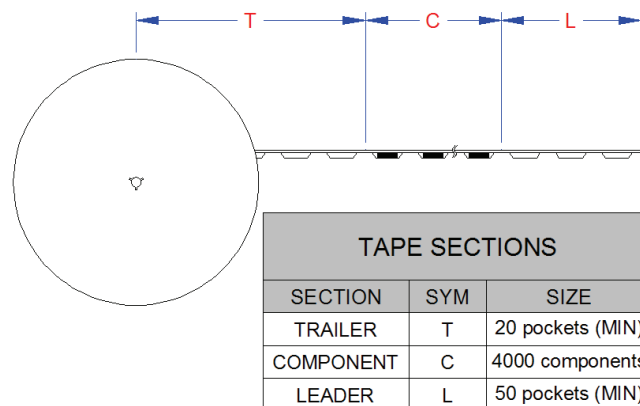

Figure 12.11 Tape Length and Part Quantity

Note: Standard reel size is 4,000 pieces per reel.

USB3503

Chapter 13 Datasheet Revision History

Table 13.1 Revision History

REVISION LEVEL	SECTION/FIGURE/ENTRY	CORRECTION
REV A replaces the previous SMSC version 1.2.		
Rev. 1.2 (08-22-13)	All	Added 32-SQFN pinout and package information
Rev. 1.1 (02-07-13)	Document co-branded: Microchip logo added, company disclaimer modified.	
Rev. 1.1 (12-19-11)	Table 4.2, "Timing Parameters for Hub Stages"	Removed the second sentence in the Standby Summary: "All port interfaces are high impedance"
	Section 4.2.1, "External Hardware RESET_N"	Removed second bullet: "The USB data pins will be in a high-impedance state."
	Table 3.4, "USB3503 Secondary Reference Clock Frequencies"	Changed Frequency values in Table 3.4 as follows: 01 = 27.0MHz 10 = 25.0MHz
Rev. 1.0 (10-24-11)	Document release	

Note the following details of the code protection feature on Microchip devices:

- Microchip products meet the specification contained in their particular Microchip Data Sheet.
- Microchip believes that its family of products is one of the most secure families of its kind on the market today, when used in the intended manner and under normal conditions.
- There are dishonest and possibly illegal methods used to breach the code protection feature. All of these methods, to our knowledge, require using the Microchip products in a manner outside the operating specifications contained in Microchip's Data Sheets. Most likely, the person doing so is engaged in theft of intellectual property.
- Microchip is willing to work with the customer who is concerned about the integrity of their code.
- Neither Microchip nor any other semiconductor manufacturer can guarantee the security of their code. Code protection does not mean that we are guaranteeing the product as "unbreakable."

Code protection is constantly evolving. We at Microchip are committed to continuously improving the code protection features of our products. Attempts to break Microchip's code protection feature may be a violation of the Digital Millennium Copyright Act. If such acts allow unauthorized access to your software or other copyrighted work, you may have a right to sue for relief under that Act.

Information contained in this publication regarding device applications and the like is provided only for your convenience and may be superseded by updates. It is your responsibility to ensure that your application meets with your specifications. MICROCHIP MAKES NO REPRESENTATIONS OR WARRANTIES OF ANY KIND WHETHER EXPRESS OR IMPLIED, WRITTEN OR ORAL, STATUTORY OR OTHERWISE, RELATED TO THE INFORMATION, INCLUDING BUT NOT LIMITED TO ITS CONDITION, QUALITY, PERFORMANCE, MERCHANTABILITY OR FITNESS FOR PURPOSE. Microchip disclaims all liability arising from this information and its use. Use of Microchip devices in life support and/or safety applications is entirely at the buyer's risk, and the buyer agrees to defend, indemnify and hold harmless Microchip from any and all damages, claims, suits, or expenses resulting from such use. No licenses are conveyed, implicitly or otherwise, under any Microchip intellectual property rights.

Trademarks

The Microchip name and logo, the Microchip logo, dsPIC, FlashFlex, KEELOQ, KEELOQ logo, MPLAB, PIC, PICmicro, PICSTART, PIC³² logo, rPIC, SST, SST Logo, SuperFlash and UNI/O are registered trademarks of Microchip Technology Incorporated in the U.S.A. and other countries.

FilterLab, Hampshire, HI-TECH C, Linear Active Thermistor, MTP, SEEVAL and The Embedded Control Solutions Company are registered trademarks of Microchip Technology Incorporated in the U.S.A.

Silicon Storage Technology is a registered trademark of Microchip Technology Inc. in other countries.

Analog-for-the-Digital Age, Application Maestro, BodyCom, chipKIT, chipKIT logo, CodeGuard, dsPICDEM, dsPICDEM.net, dsPICworks, dsSPEAK, ECAN, ECONOMONITOR, FanSense, HI-TIDE, In-Circuit Serial Programming, ICSP, Mindi, MiWi, MPASM, MPF, MPLAB Certified logo, MPLIB, MPLINK, mTouch, Omniscient Code Generation, PICC, PICC-18, PICDEM, PICDEM.net, PICKit, PICtail, REAL ICE, rLAB, Select Mode, SQI, Serial Quad I/O, Total Endurance, TSHARC, UniWinDriver, WiperLock, ZENA and Z-Scale are trademarks of Microchip Technology Incorporated in the U.S.A. and other countries.

SQTP is a service mark of Microchip Technology Incorporated in the U.S.A.

GestIC and ULPP are registered trademarks of Microchip Technology Germany II GmbH & Co. KG, a subsidiary of Microchip Technology Inc., in other countries.

A more complete list of registered trademarks and common law trademarks owned by Standard Microsystems Corporation ("SMSC") is available at: www.smsc.com. The absence of a trademark (name, logo, etc.) from the list does not constitute a waiver of any intellectual property rights that SMSC has established in any of its trademarks.

All other trademarks mentioned herein are property of their respective companies.

© 2013, Microchip Technology Incorporated, Printed in the U.S.A., All Rights Reserved.

ISBN: 9781620774946

QUALITY MANAGEMENT SYSTEM
CERTIFIED BY DNV
== ISO/TS 16949 ==

Microchip received ISO/TS-16949:2009 certification for its worldwide headquarters, design and wafer fabrication facilities in Chandler and Tempe, Arizona; Gresham, Oregon and design centers in California and India. The Company's quality system processes and procedures are for its PIC[®] MCUs and dsPIC[®] DSCs, KEELOQ[®] code hopping devices, Serial EEPROMs, microperipherals, nonvolatile memory and analog products. In addition, Microchip's quality system for the design and manufacture of development systems is ISO 9001:2000 certified.



MICROCHIP

Worldwide Sales and Service

AMERICAS

Corporate Office

2355 West Chandler Blvd.
Chandler, AZ 85224-6199
Tel: 480-792-7200
Fax: 480-792-7277
Technical Support:
<http://www.microchip.com/support>
Web Address:
www.microchip.com

Atlanta

Duluth, GA
Tel: 678-957-9614
Fax: 678-957-1455

Boston

Westborough, MA
Tel: 774-760-0087
Fax: 774-760-0088

Chicago

Itasca, IL
Tel: 630-285-0071
Fax: 630-285-0075

Cleveland

Independence, OH
Tel: 216-447-0464
Fax: 216-447-0643

Dallas

Addison, TX
Tel: 972-818-7423
Fax: 972-818-2924

Detroit

Farmington Hills, MI
Tel: 248-538-2250
Fax: 248-538-2260

Indianapolis

Noblesville, IN
Tel: 317-773-8323
Fax: 317-773-5453

Los Angeles

Mission Viejo, CA
Tel: 949-462-9523
Fax: 949-462-9608

Santa Clara

Santa Clara, CA
Tel: 408-961-6444
Fax: 408-961-6445

Toronto

Mississauga, Ontario,
Canada
Tel: 905-673-0699
Fax: 905-673-6509

ASIA/PACIFIC

Asia Pacific Office

Suites 3707-14, 37th Floor
Tower 6, The Gateway
Harbour City, Kowloon
Hong Kong
Tel: 852-2401-1200
Fax: 852-2401-3431

Australia - Sydney

Tel: 61-2-9868-6733
Fax: 61-2-9868-6755

China - Beijing

Tel: 86-10-8569-7000
Fax: 86-10-8528-2104

China - Chengdu

Tel: 86-28-8665-5511
Fax: 86-28-8665-7889

China - Chongqing

Tel: 86-23-8980-9588
Fax: 86-23-8980-9500

China - Hangzhou

Tel: 86-571-2819-3187
Fax: 86-571-2819-3189

China - Hong Kong SAR

Tel: 852-2943-5100
Fax: 852-2401-3431

China - Nanjing

Tel: 86-25-8473-2460
Fax: 86-25-8473-2470

China - Qingdao

Tel: 86-532-8502-7355
Fax: 86-532-8502-7205

China - Shanghai

Tel: 86-21-5407-5533
Fax: 86-21-5407-5066

China - Shenyang

Tel: 86-24-2334-2829
Fax: 86-24-2334-2393

China - Shenzhen

Tel: 86-755-8864-2200
Fax: 86-755-8203-1760

China - Wuhan

Tel: 86-27-5980-5300
Fax: 86-27-5980-5118

China - Xian

Tel: 86-29-8833-7252
Fax: 86-29-8833-7256

China - Xiamen

Tel: 86-592-2388138
Fax: 86-592-2388130

China - Zhuhai

Tel: 86-756-3210040
Fax: 86-756-3210049

ASIA/PACIFIC

India - Bangalore

Tel: 91-80-3090-4444
Fax: 91-80-3090-4123

India - New Delhi

Tel: 91-11-4160-8631
Fax: 91-11-4160-8632

India - Pune

Tel: 91-20-3019-1500

Japan - Osaka

Tel: 81-6-6152-7160
Fax: 81-6-6152-9310

Japan - Tokyo

Tel: 81-3-6880-3770
Fax: 81-3-6880-3771

Korea - Daegu

Tel: 82-53-744-4301
Fax: 82-53-744-4302

Korea - Seoul

Tel: 82-2-554-7200
Fax: 82-2-558-5932 or
82-2-558-5934

Malaysia - Kuala Lumpur

Tel: 60-3-6201-9857
Fax: 60-3-6201-9859

Malaysia - Penang

Tel: 60-4-227-8870
Fax: 60-4-227-4068

Philippines - Manila

Tel: 63-2-634-9065
Fax: 63-2-634-9069

Singapore

Tel: 65-6334-8870
Fax: 65-6334-8850

Taiwan - Hsin Chu

Tel: 886-3-5778-366
Fax: 886-3-5770-955

Taiwan - Kaohsiung

Tel: 886-7-213-7828
Fax: 886-7-330-9305

Taiwan - Taipei

Tel: 886-2-2508-8600
Fax: 886-2-2508-0102

Thailand - Bangkok

Tel: 66-2-694-1351
Fax: 66-2-694-1350

EUROPE

Austria - Wels

Tel: 43-7242-2244-39
Fax: 43-7242-2244-393

Denmark - Copenhagen

Tel: 45-4450-2828
Fax: 45-4485-2829

France - Paris

Tel: 33-1-69-53-63-20
Fax: 33-1-69-30-90-79

Germany - Munich

Tel: 49-89-627-144-0
Fax: 49-89-627-144-44

Italy - Milan

Tel: 39-0331-742611
Fax: 39-0331-466781

Netherlands - Drunen

Tel: 31-416-690399
Fax: 31-416-690340

Spain - Madrid

Tel: 34-91-708-08-90
Fax: 34-91-708-08-91

UK - Wokingham

Tel: 44-118-921-5869
Fax: 44-118-921-5820

08/20/13

Mouser Electronics

Authorized Distributor

Click to View Pricing, Inventory, Delivery & Lifecycle Information:

[Microchip:](#)

[USB3503T/ML](#) [USB3503-I/ML](#) [USB3503/ML](#) [USB3503T-I/ML](#) [USB3503AI-1-GL-TR](#)