

## 2 A max constant current LED driver

### Features

- Up to 40 V input voltage
- Less than 0.5 V voltage overhead
- Up to 2 A output current
- PWM dimming pin
- Shutdown pin
- LED disconnection diagnostic

### Applications

- LED constant current supplying for varying input voltages
- Low voltage lighting
- Small appliances LED lighting
- Car LED lights

### Description

The STCS2 is a BiCMOS constant current source designed to provide a precise constant current starting from a varying input voltage source. The main target is to replace discrete components solution for driving LEDs in low voltage applications such as 5 V, 12 V or 24 V giving benefits in terms of precision, integration and reliability.

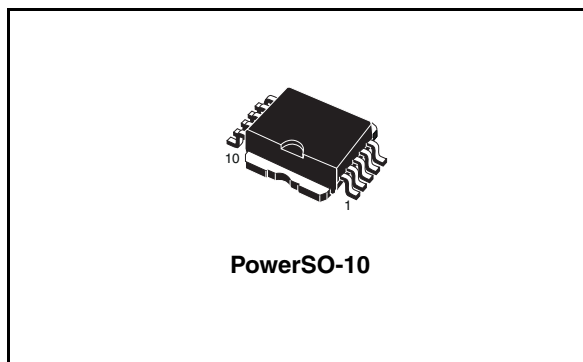

The current is set with external resistor up to 2 A with a  $\pm 10\%$  precision; a dedicated pin allows implementing PWM dimming.

An open-drain pin output provides information on load disconnection condition.

**Table 1. Device summary**

Order code	Package	Packaging
STCS2SPR	PowerSO-10	600 parts per reel

# Contents

<b>1</b>	<b>Application diagram</b> .....	<b>3</b>
<b>2</b>	<b>Pin configuration</b> .....	<b>4</b>
<b>3</b>	<b>Maximum ratings</b> .....	<b>5</b>
<b>4</b>	<b>Electrical characteristics</b> .....	<b>6</b>
<b>5</b>	<b>Timing</b> .....	<b>7</b>
<b>6</b>	<b>Typical performance characteristics</b> .....	<b>8</b>
<b>7</b>	<b>Detail description</b> .....	<b>9</b>
	7.1 Current setting .....	9
	7.2 Enable .....	9
	7.3 PWM dimming .....	9
	7.4 Diagnostic .....	9
<b>8</b>	<b>Application information</b> .....	<b>10</b>
	8.1 Reverse polarity protection .....	10
	8.2 Thermal considerations .....	10
<b>9</b>	<b>Package mechanical data</b> .....	<b>12</b>
<b>10</b>	<b>Revision history</b> .....	<b>15</b>

# 1 Application diagram

Figure 1. Typical application diagram for 2 A LED current

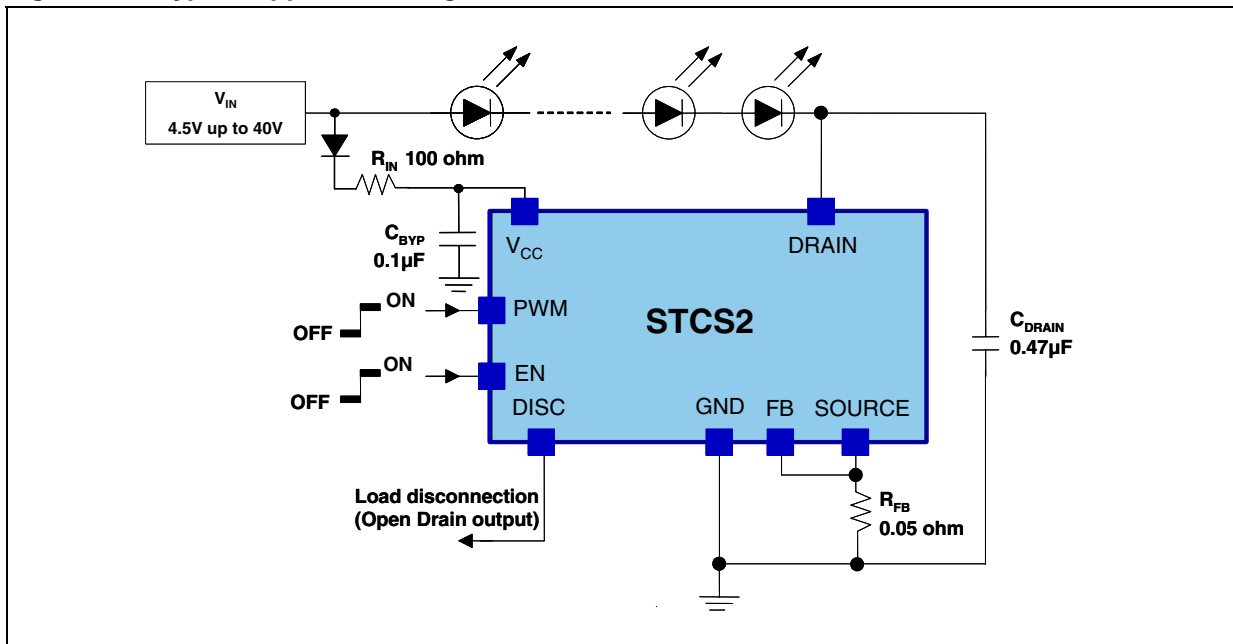

## 2 Pin configuration

Figure 2. Pin connections (top view)

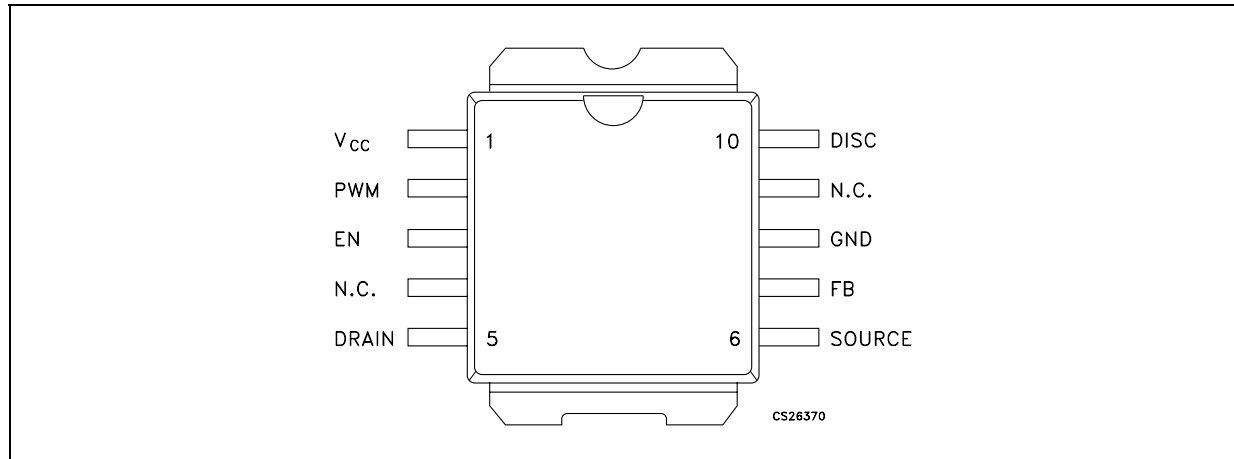

Table 2. Pin description

Pin n°	Symbol	Note
1	V <sub>CC</sub>	Supply voltage
2	PWM	PWM dimming input
3	EN	Shutdown
4	N.C.	Not connected
5	DRAIN	Internal N-MOSFET drain
6	SOURCE	Internal N-MOSFET SOURCE. Reference voltage is 100 mV. An external resistor between SOURCE and GND pins sets different current levels for different application needs
7	FB	Feedback input. The control loop regulates the current in such a way that the average voltage at the FB input is 100 mV (nominal). The cathode of the LED and a resistor to ground to set the LED current should be connected at this point
8	GND	Ground
9	N.C.	In order to guarantee the device works properly it is mandatory to leave this pin floating
10	DISC	Load disconnection flag (open drain)
	Exp-pad	Internally connected to ground

### 3 Maximum ratings

**Table 3. Absolute maximum ratings**

Symbol	Parameter	Value	Unit
$V_{CC}$	DC supply voltage	-0.3 to +45	V
DRAIN	Drain pin	-0.3 to +45	
SOURCE	Source pin	-0.3 to + 3.3	V
PWM, EN, DISC	Logic pins	-0.3 to + $V_{CC} + 0.3$	V
FB	Configuration pins	-0.3 to + 3.3	V
ESD	Human body model (all pins)	$\pm 2$	kV
$T_J^{(1)}$	Junction temperature	-40 to 150	$^{\circ}\text{C}$
$T_{STG}$	Storage temperature range	-55 to 150	$^{\circ}\text{C}$

1.  $T_J$  is calculated from the ambient temperature  $T_A$  and the power dissipation  $P_D$  according the following formula:  
 $T_J = T_A + (P_D \times R_{thJA})$ . See [Figure 12](#) for details of max power dissipation for ambient temperatures higher than 25 $^{\circ}\text{C}$ .

*Note: Absolute maximum ratings are those values beyond which damage to the device may occur. Functional operation under these conditions is not implied.*

**Table 4. Thermal data**

Symbol	Parameter	PowerSO-10	Unit
$R_{thJC}$	Thermal resistance junction-case	2	$^{\circ}\text{C}/\text{W}$
$R_{thJA}^{(1)}$	Thermal resistance junction-ambient <sup>(1)</sup>	50	$^{\circ}\text{C}/\text{W}$
$R_{thJA}^{(2)}$	Thermal resistance junction-ambient <sup>(2)</sup>	35	$^{\circ}\text{C}/\text{W}$
$R_{thJA}^{(3)}$	Thermal resistance junction-ambient <sup>(3)</sup>	12	$^{\circ}\text{C}/\text{W}$

- FR4 with using the recommended pad-layout
- FR4 with heat sink on board (6 cm<sup>2</sup>).
- FR4 with copper-filled through holes and external heat sink applied.

## 4 Electrical characteristics

**Table 5. Electrical characteristics**

( $V_{CC} = 12\text{ V}$ ;  $I_O = 100\text{ mA}$ ;  $T_J = -40\text{ }^\circ\text{C}$  to  $125\text{ }^\circ\text{C}$ ;  $V_{DRAIN} = 1\text{ V}$ ;  $C_{DRAIN} = 1\text{ }\mu\text{F}$ ;  $C_{BYP} = 100\text{ nF}$  typical values are at  $T_A = 25\text{ }^\circ\text{C}$ , unless otherwise specified)

Symbol	Parameter	Test conditions	Min.	Typ.	Max.	Unit	
$V_{CC}$	Supply voltage range		4.5		40	V	
	Output current range		1		2000	mA	
$I_O$	Output current	$R_{FB} = 50\text{ m}\Omega$		2		A	
	Regulation (percentage with respect to $V_{CC}=12\text{V}$ )	$V_{CC} = 4.5\text{ to }40\text{ V}$ , $I_O = 100\text{ mA}$ ; $V_{DRAIN} = 1\text{ V}$	-1		+1	%	
$V_{FB}$	Feedback voltage	$I_O = 0\text{ to }2\text{ A}$	90	100	110	mV	
$I_{CC}$	Quiescent current (Measured on $V_{CC}$ pin)	On Mode		450	750	$\mu\text{A}$	
		Shutdown Mode; $V_{CC} = 5\text{ to }12\text{ V}$			1		
		Shutdown Mode; $V_{CC} = 12\text{ to }40\text{ V}$			3		
$V_{DROP}$	Dropout voltage ( $V_{DRAIN}$ to GND)	$I_O = 100\text{ mA}$		0.12	0.16	V	
		$I_O = 2\text{ A}$		0.58	0.9		
$LEAK_{DRAIN}$	Drain leakage current	Shutdown; $V_{DRAIN} = 40\text{ V}$			10	$\mu\text{A}$	
$T_D$	Delay on PWM signal (see fig.1)	$V_{PWM}$ rising, $V_{CC} = 12\text{ V}$		3		$\mu\text{s}$	
		$V_{PWM}$ falling, $V_{CC} = 12\text{ V}$		1.2			
DISC	Low level voltage	$I_{SINK} = 5\text{ mA}$		0.2	0.5	V	
	Leakage current	$V_{DISC} = 5\text{ V}$			1	$\mu\text{A}$	
	Load disconnection threshold ( $V_{DRAIN}-\text{GND}$ )	DISC Turn-ON			75		mV
		DISC Turn-OFF			110		
Thermal Protection	Shutdown temperature			155		$^\circ\text{C}$	
	Hysteresis			25			
<b>Logic inputs (PWM and EN)</b>							
$V_L$	Input low level				0.4	V	
$V_H$	Input high level		1.2			V	
	EN, PWM leakage current	$V_{EN} = 5\text{ V}$ ; $V_{PWM} = 5\text{ V}$			2	$\mu\text{A}$	
	EN input leakage current	$V_{EN} = 40\text{ V}$			60		
	PWM input leakage current	$V_{PWM} = 40\text{ V}$			120		

*Note:* All devices 100 % production tested at  $T_A = 25\text{ }^\circ\text{C}$ . Limits over the operating temperature range are guaranteed by design.

# 5 Timing

Figure 3. PWM and output current timing



Figure 4. Block diagram

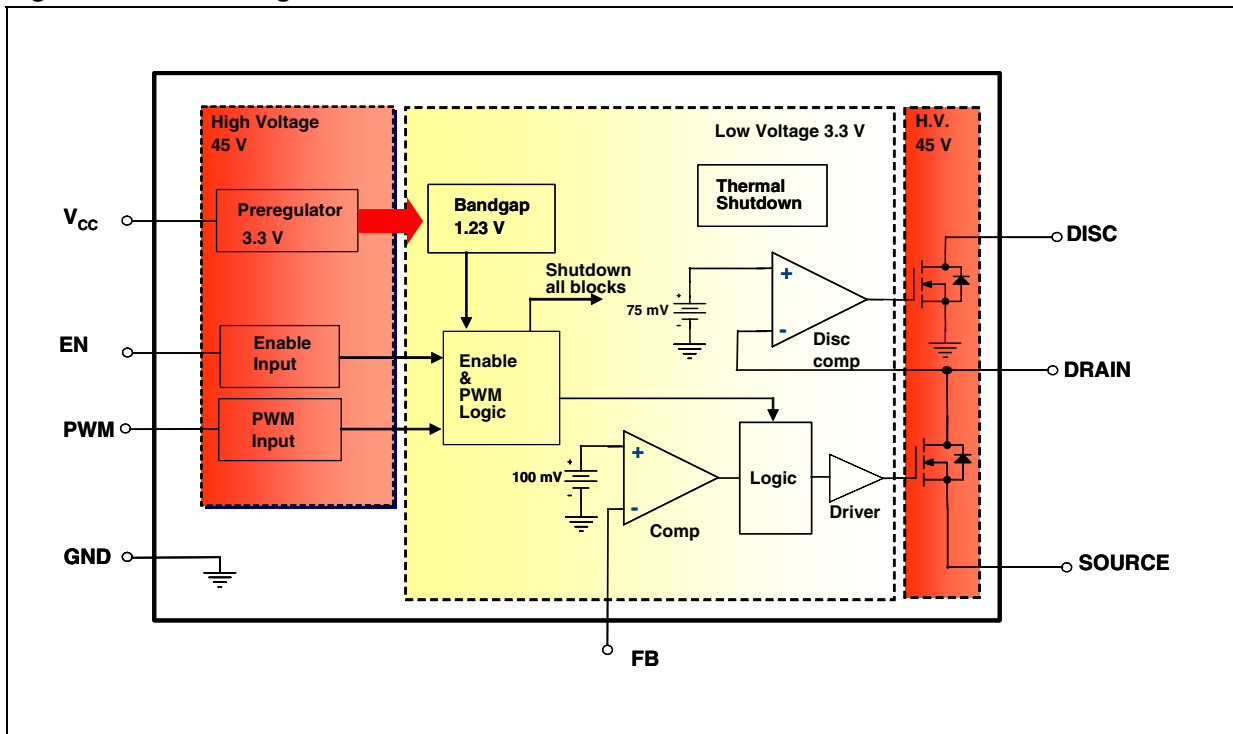

# 6 Typical performance characteristics

Figure 5.  $I_{DRAIN}$  vs  $V_{CC}$ ,  $T_A = 25\text{ }^\circ\text{C}$



Figure 6.  $I_{DRAIN}$  vs  $R_{SET}$



Figure 7.  $I_{DRAIN}$  vs temperature



Figure 8.  $V_{DROP}$  (including  $V_{FB}$ ) vs temperature



Figure 9.  $I_{CC}$  vs temperature



Figure 10.  $I_{CC}$  vs  $V_{CC}$





## 7 Detail description

The STCS2 is a BiCMOS constant current source designed to provide a precise constant current starting from a varying input voltage source. The main target is to replace discrete components solution for driving LEDs in low voltage applications such as 5 V, 12 V or 24 V giving benefits in terms of precision, integration and reliability.

### 7.1 Current setting

The current is set with an external sensing resistor connected to the FB pin. The feedback voltage is 100 mV, then a low resistor value can be chosen reducing power dissipation. A value between 1 mA and 2 A can be set according to the resistor value the resulting output current has a tolerance of  $\pm 10\%$ .

For instance, should one need a 700 mA LEDs current,  $R_F$  should be selected according to the following equation:

$$R_F = V_{FB} / I_{LEDs} = 100 \text{ mV} / 700 \text{ mA} = 142 \text{ m}\Omega$$

### 7.2 Enable

When the enable pin is low the device completely off thus reducing current consumption to less than 1  $\mu$ A. When in shutdown mode, the internal main switch is off.

### 7.3 PWM dimming

The PWM input allows implementing PWM dimming on the LED current; when the PWM input is high the main switch will be on and vice versa. A typical frequency range for the input is from few Hertz to 50 kHz. The maximum dimming frequency is limited by the minimum rise/fall time of the current which is around 4  $\mu$ s each. Above 50 kHz the current waveforms starts assuming a triangular shape.

While the PWM input is switching, the overall circuitry remains on, this is needed in order to implement a short delay time  $T_D$  (see [Figure 3](#)).

Since the PWM pin is controlling just the main switch, the overall circuitry is always on and it is able to control the delay time between the PWM input signal and the output current in the range of few  $\mu$ s, this is important to implement synchronization among several light LED sources.

### 7.4 Diagnostic

When STCS2 is in on mode (EN is high), the device is able to detect disconnection or fail of the LED string monitoring  $V_{DRAIN}$  pin. If  $V_{DRAIN}$  is lower than 75 mV the DISC pin is pulled low regardless the PWM pin status. This information can be used by the system to inform that some problem happens in the LEDs.

## 8 Application information

### 8.1 Reverse polarity protection

STCS2 must be protected from reverse connection of the supply voltage. Since the current sunk from  $V_{CC}$  pin is in the range of  $450 \mu\text{A}$  a small diode connected to  $V_{CC}$  is able to protect the chip. Care must be taken for the whole application circuit, especially for the LEDs, in fact, in case a negative voltage is applied between  $V_{IN}$  and GND, a negative voltage will be applied to the LED string that must have a total breakdown voltage higher than the negative applied voltage in order to avoid any damage.

Figure 11. Reverse polarity condition

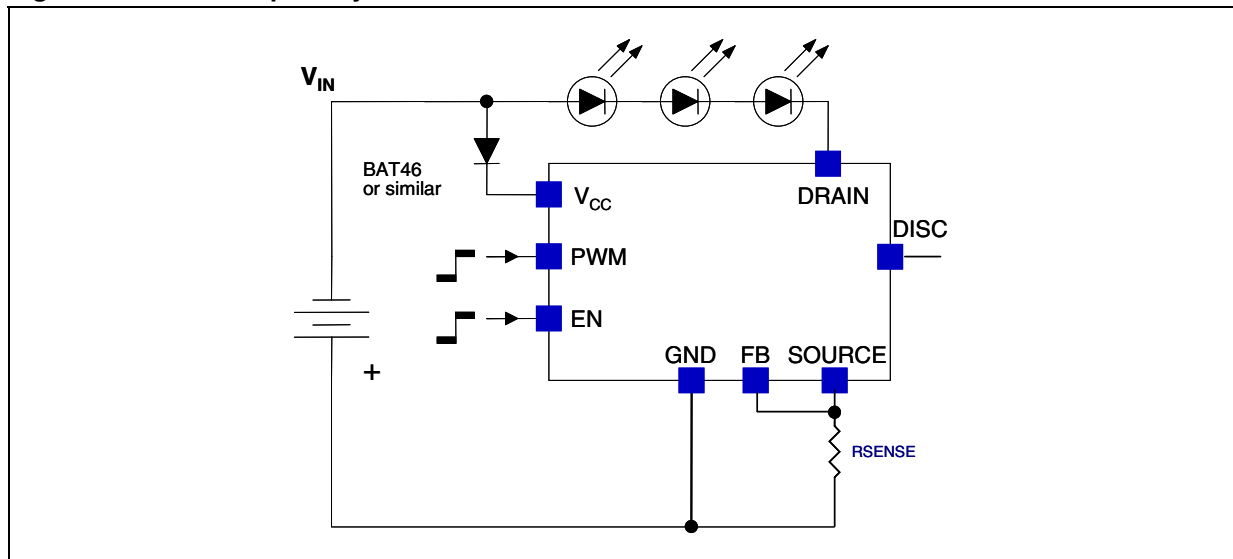

### 8.2 Thermal considerations

The STCS2 is able to control a LED current up to 2 A and able to sustain a voltage on the drain pin up to 40 V. Those operating conditions are however limited by thermal constraints.

The poor thermal conduction of epoxy FR4 boards does not permit to benefit of the outstanding thermal performance of the PowerSO-10.

In any case one way to improve the thermal conduction is the use of large heat spreader areas at the copper layer of the PC board. This leads to a reduction of thermal resistance to  $30 - 36^\circ\text{C/W}$  for  $3$  to  $6 \text{ cm}^2$  on-board heatsink.

Use of copper-filled through holes on conventional FR4 techniques increases the metallization and decreases thermal resistance accordingly. Using a configuration with 16 holes under the spreader of the package with a pitch of 1.8 mm and a diameter of 0.7 mm, the thermal resistance (junction - heatsink) can be reduced to  $12^\circ\text{C/W}$ .

The thermal resistances shown in the Error! Reference source not found. section are the typical ones.

The power dissipation in the device can be calculated as follow:

$$P_D = (V_{\text{DRAIN}} - V_{\text{FB}}) \times I_{\text{LED}} + (V_{\text{CC}} \times I_{\text{CC}})$$

basing on this and on the thermal resistance and ambient temperature, the junction temperature can be calculated as:

$$T_J = R_{thJA} \times P_D + T_A$$

A typical application could be:

- Input Voltage: 12 V;
- 3 white LEDs with an typical  $V_F = 3.6$  V;
- LEDs current: 1000 mA;
- Package: Power SO-10;
- $T_A = 50$  °C;

In this case the drain voltage is given by:

$$V_{DRAIN} = 12 - 3 \times 3.6 = 1.2 \text{ V}$$

end the power dissipated in the IC is the following:

$$P_D = (1.2 - 0.1) \times 1 + 12 \times 0.5 \times 10^{-3} = 1.1 \text{ W}$$

With a thermal resistance junction-ambient equal to 12 °C/W the junction temperature is:

$$T_J = 12 \times 1.1 + 50 = 63 \text{ °C.}$$

The following pictures show the maximum power dissipation according to the ambient temperature:

**Figure 12. Maximum power dissipation vs  $T_A$  for PowerSO-10**

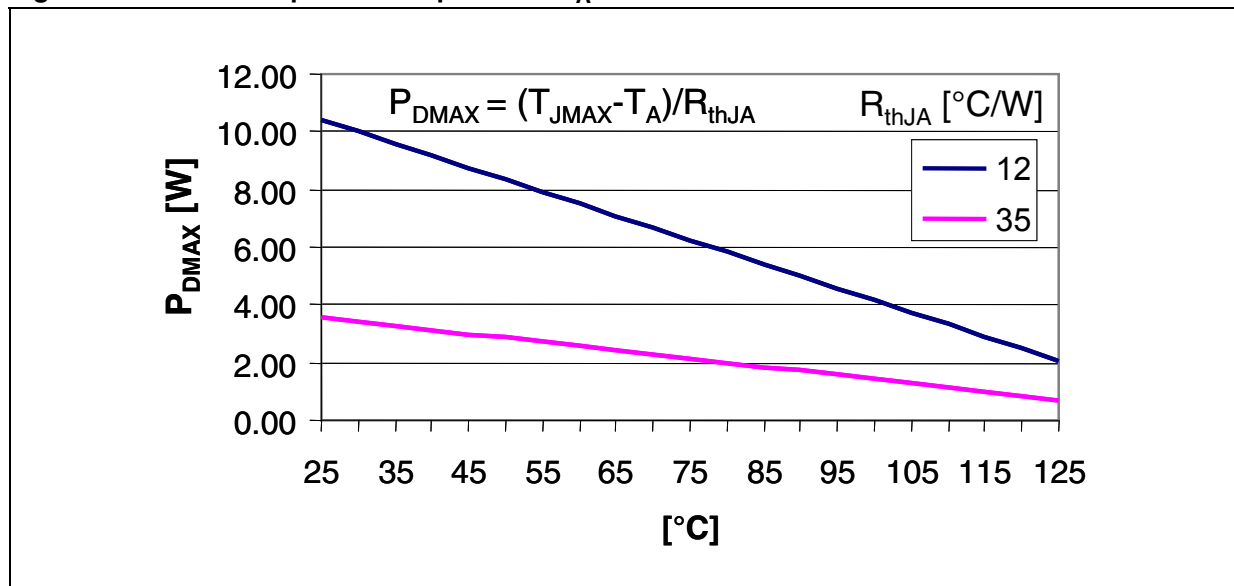

## 9 Package mechanical data

In order to meet environmental requirements, ST offers these devices in ECOPACK<sup>®</sup> packages. These packages have a lead-free second level interconnect. The category of second Level Interconnect is marked on the package and on the inner box label, in compliance with JEDEC Standard JESD97. The maximum ratings related to soldering conditions are also marked on the inner box label. ECOPACK is an ST trademark. ECOPACK specifications are available at: [www.st.com](http://www.st.com).

**PowerSO-10 mechanical data**

Dim.	mm.			inch.		
	Min.	Typ.	Max.	Min.	Typ.	Max.
A			3.70			0.146
A1			0.10			0.004
A2	3.40		3.60	0.134		0.142
A3	1.25		1.35	0.049		0.053
b	0.40		0.53	0.016		0.021
c	0.35		0.55	0.014		0.022
D	9.40		9.60	0.370		0.378
D1	7.40		7.60	0.291		0.299
E	13.80		14.40	0.543		0.567
E1	9.30		9.50	0.366		0.374
E2	7.20		7.60	0.283		0.299
E3	5.90		6.10	0.232		0.240
e		1.27			0.050	
L	0.95		1.65	0.037		0.065
$\alpha$	0°		8°	0°		8°

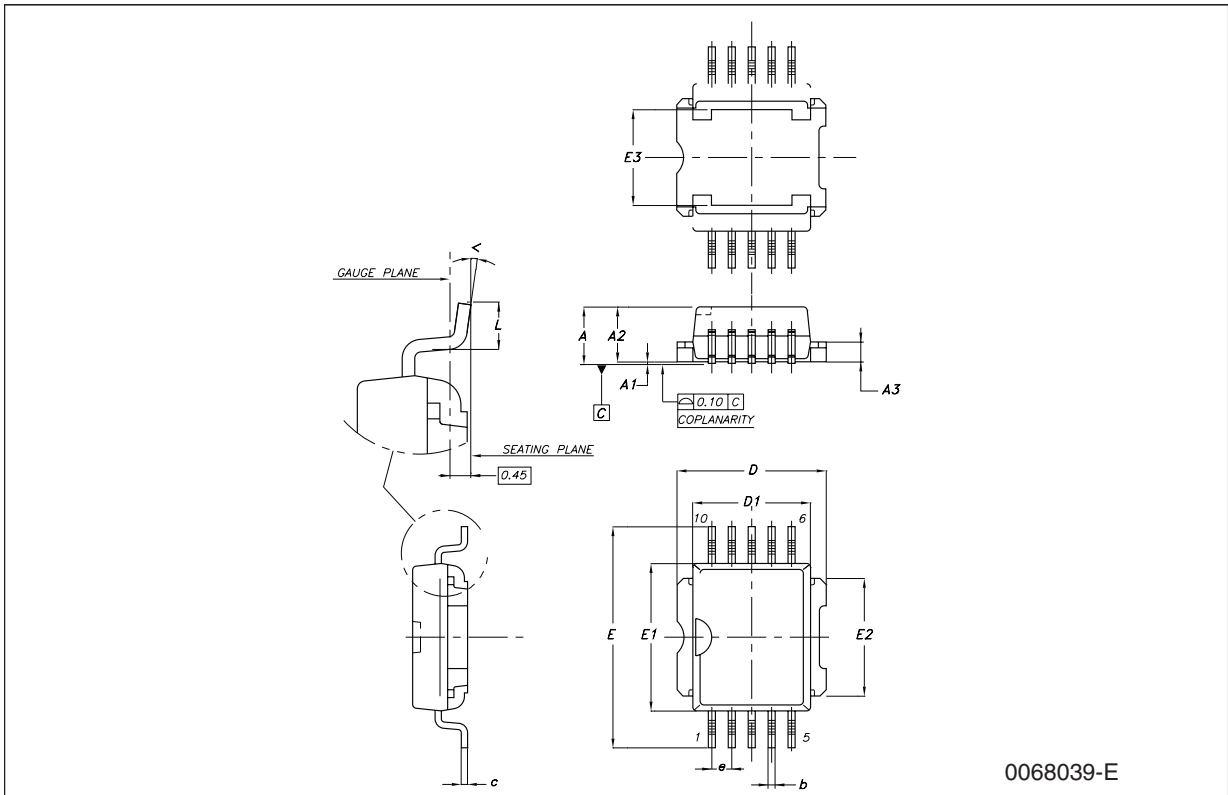

**Tape & reel PowerSO-10 mechanical data**

Dim.	mm.			inch.		
	Min.	Typ.	Max.	Min.	Typ.	Max.
A			330			12.992
C	12.8		13.2	0.504		0.519
D	20.2			0.795		
N	60			2.362		
T			30.4			1.197
Ao	14.9		15.1	0.587		0.594
Bo	9.9		10.1	0.390		0.398
Ko	4.15		4.35	0.163		0.171
Po	3.9		4.1	0.153		0.161
P	23.9		24.1	0.941		0.949
W	23.7		24.3	0.933		0.957

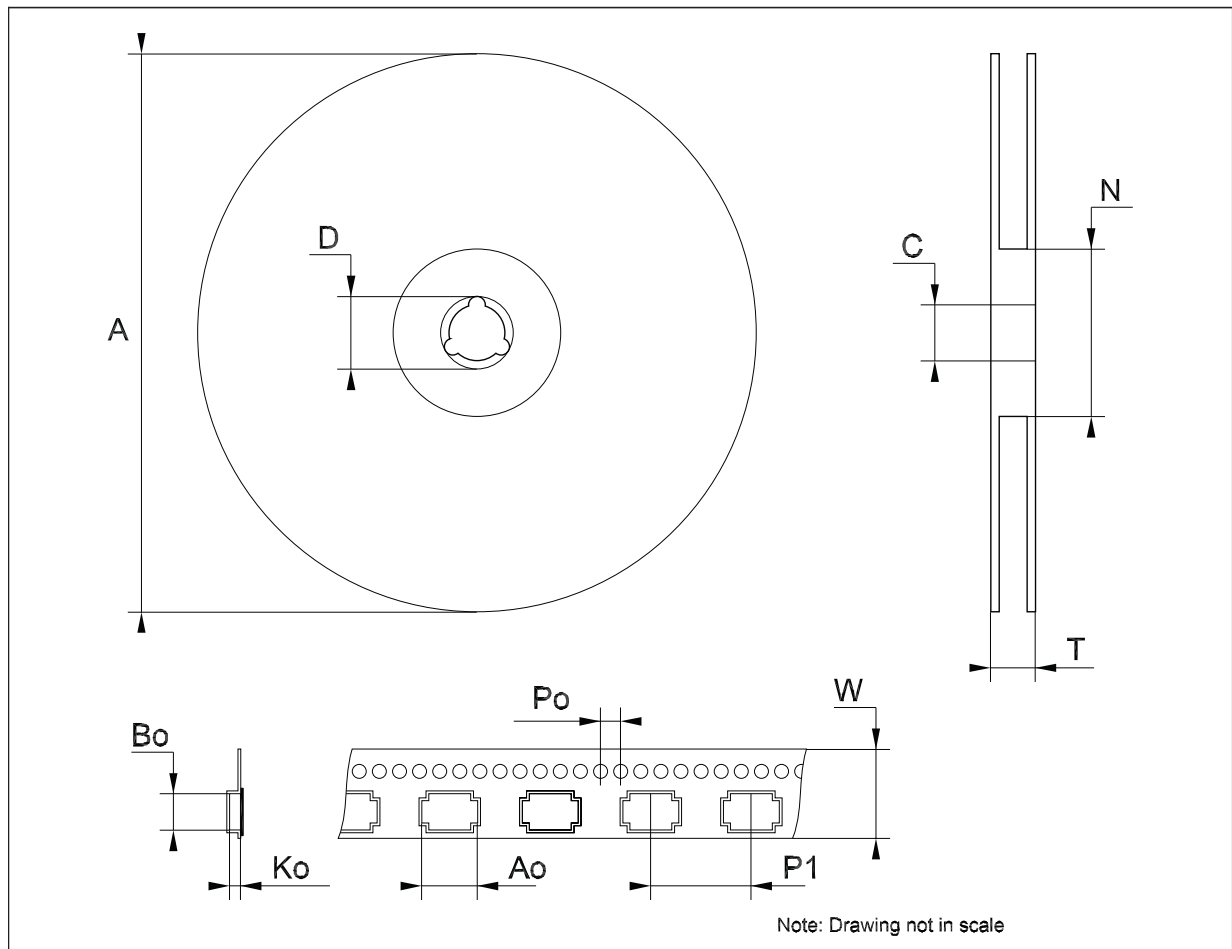

## 10 Revision history

**Table 6. Document revision history**

Date	Revision	Changes
03-Oct-2007	1	Initial release.
15-Feb-2008	2	Modified: <i>Figure 1 on page 3, Figure 4 on page 7, Figure 12 on page 11.</i>
05-May-2008	3	Modified: <i>Table 2 on page 4</i> , pin 9 description.
02-Jul-2008	4	Modified: <i>Table 5 on page 6.</i>

**Please Read Carefully:**

Information in this document is provided solely in connection with ST products. STMicroelectronics NV and its subsidiaries ("ST") reserve the right to make changes, corrections, modifications or improvements, to this document, and the products and services described herein at any time, without notice.

All ST products are sold pursuant to ST's terms and conditions of sale.

Purchasers are solely responsible for the choice, selection and use of the ST products and services described herein, and ST assumes no liability whatsoever relating to the choice, selection or use of the ST products and services described herein.

No license, express or implied, by estoppel or otherwise, to any intellectual property rights is granted under this document. If any part of this document refers to any third party products or services it shall not be deemed a license grant by ST for the use of such third party products or services, or any intellectual property contained therein or considered as a warranty covering the use in any manner whatsoever of such third party products or services or any intellectual property contained therein.

**UNLESS OTHERWISE SET FORTH IN ST'S TERMS AND CONDITIONS OF SALE ST DISCLAIMS ANY EXPRESS OR IMPLIED WARRANTY WITH RESPECT TO THE USE AND/OR SALE OF ST PRODUCTS INCLUDING WITHOUT LIMITATION IMPLIED WARRANTIES OF MERCHANTABILITY, FITNESS FOR A PARTICULAR PURPOSE (AND THEIR EQUIVALENTS UNDER THE LAWS OF ANY JURISDICTION), OR INFRINGEMENT OF ANY PATENT, COPYRIGHT OR OTHER INTELLECTUAL PROPERTY RIGHT.**

**UNLESS EXPRESSLY APPROVED IN WRITING BY AN AUTHORIZED ST REPRESENTATIVE, ST PRODUCTS ARE NOT RECOMMENDED, AUTHORIZED OR WARRANTED FOR USE IN MILITARY, AIR CRAFT, SPACE, LIFE SAVING, OR LIFE SUSTAINING APPLICATIONS, NOR IN PRODUCTS OR SYSTEMS WHERE FAILURE OR MALFUNCTION MAY RESULT IN PERSONAL INJURY, DEATH, OR SEVERE PROPERTY OR ENVIRONMENTAL DAMAGE. ST PRODUCTS WHICH ARE NOT SPECIFIED AS "AUTOMOTIVE GRADE" MAY ONLY BE USED IN AUTOMOTIVE APPLICATIONS AT USER'S OWN RISK.**

Resale of ST products with provisions different from the statements and/or technical features set forth in this document shall immediately void any warranty granted by ST for the ST product or service described herein and shall not create or extend in any manner whatsoever, any liability of ST.

ST and the ST logo are trademarks or registered trademarks of ST in various countries.

Information in this document supersedes and replaces all information previously supplied.

The ST logo is a registered trademark of STMicroelectronics. All other names are the property of their respective owners.

© 2008 STMicroelectronics - All rights reserved

STMicroelectronics group of companies

Australia - Belgium - Brazil - Canada - China - Czech Republic - Finland - France - Germany - Hong Kong - India - Israel - Italy - Japan - Malaysia - Malta - Morocco - Singapore - Spain - Sweden - Switzerland - United Kingdom - United States of America

[www.st.com](http://www.st.com)



# Mouser Electronics

Authorized Distributor

Click to View Pricing, Inventory, Delivery & Lifecycle Information:

[STMicroelectronics:](#)

[STCS2SPR](#)