

Optocoupler, Phototransistor Output, No Base Connection

Features

- High Isolation Voltage, 5300 V_{RMS}
- No Base Terminal Connection for Improved Common Mode Interface Immunity
- Long Term Stability
- Industry Standard Dual-in-Line Package
- Lead-free component
- Component in accordance to RoHS 2002/95/EC and WEEE 2002/96/EC

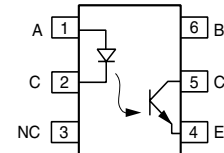
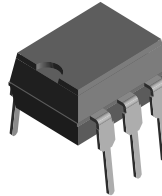

1179009



Agency Approvals

- UL1577, File No. E52744 System Code H or J, Double Protection
- CSA 93751
- BSI IEC60950 IEC60065
- DIN EN 60747-5-2 (VDE0884)
DIN EN 60747-5-5 pending
Available with Option 1

Description

The MOC8101/ 2/ 3/ 4/ 5 family optocoupler consisting of a Gallium Arsenide infrared emitting diode optically coupled to a silicon planar phototransistor detector in a plastic plug-in DIP-6 package.

The coupling device is suitable for signal transmission between two electrically separated circuits. The potential difference between the circuits to be coupled should not exceed the maximum permissible reference voltages.

The base terminal of the MOC8101/ 2/ 3/ 4/ 5 is not connected, resulting in a substantially improved common-mode interference immunity.

Order Information

Part	Remarks
MOC8101	CTR 50 - 80 %, DIP-6
MOC8102	CTR 73 - 117 %, DIP-6
MOC8103	CTR 108 - 173 %, DIP-6
MOC8104	CTR 160 - 256 %, DIP-6
MOC8105	CTR 65 - 133 %, DIP-6
MOC8101-X006	CTR 50 - 80 %, DIP-6 400 mil (option 6)
MOC8101-X007	CTR 50 - 80 %, SMD-6 (option 7)
MOC8101-X009	CTR 50 - 80 %, SMD-6 (option 9)
MOC8102-X006	CTR 73 - 117 %, DIP-6 400 mil (option 6)
MOC8102-X007	CTR 73 - 117 %, SMD-6 (option 7)
MOC8102-X009	CTR 73 - 117 %, SMD-6 (option 9)
MOC8104-X006	CTR 160 - 256 %, DIP-6 400 mil (option 6)
MOC8104-X009	CTR 160 - 256 %, SMD-6 (option 9)
MOC8105-X006	CTR 65 - 133 %, DIP-6 400 mil (option 6)
MOC8105-X009	CTR 65 - 133 %, SMD-6 (option 9)

For additional information on the available options refer to Option Information.

Absolute Maximum Ratings

$T_{amb} = 25\text{ }^{\circ}\text{C}$, unless otherwise specified

Stresses in excess of the absolute Maximum Ratings can cause permanent damage to the device. Functional operation of the device is not implied at these or any other conditions in excess of those given in the operational sections of this document. Exposure to absolute Maximum Rating for extended periods of the time can adversely affect reliability.

Input

Parameter	Test condition	Symbol	Value	Unit
Reverse voltage		V_R	6.0	V
Forward continuous current		I_F	60	mA
Surge forward current	$t \leq 10\text{ }\mu\text{s}$	I_{FSM}	2.5	A
Power dissipation		P_{diss}	100	mW
Derate Linearly from 25 °C			1.33	mW/°C

Output

Parameter	Test condition	Symbol	Value	Unit
Collector-emitter breakdown voltage		BV_{CEO}	30	V
Emitter-collector breakdown voltage		BV_{ECO}	7.0	V
Collector current		I_C	50	mA
Derate linearly from 25 °C			2.00	mW/°C
Power dissipation		P_{diss}	150	mW

Coupler

Parameter	Test condition	Symbol	Value	Unit
Isolation test voltage		V_{ISO}	5300	V_{RMS}
Creepage			≥ 7.0	mm
Clearance			≥ 7.0	mm
Isolation thickness between emitter and detector			≥ 0.4	mm
Comparative tracking index per DIN IEC 112/VDE 0303, part 1			175	
Isolation resistance	$V_{IO} = 500\text{ V}$	R_{IO}	$\geq 10^{12}$	Ω
Derate linearly from 25 °C			3.33	mW/°C
Total power dissipation		P_{tot}	250	mW
Storage temperature		T_{stg}	- 55 to + 150	°C
Operating temperature		T_{amb}	- 55 to + 100	°C
Junction temperature		T_j	100	°C
Soldering temperature	max. 10 s, dip soldering: distance to seating plane $\geq 1.5\text{ mm}$	T_{sld}	260	°C



Electrical Characteristics

$T_{amb} = 25\text{ }^{\circ}\text{C}$, unless otherwise specified

Minimum and maximum values are testing requirements. Typical values are characteristics of the device and are the result of engineering evaluation. Typical values are for information only and are not part of the testing requirements.

Input

Parameter	Test condition	Symbol	Min	Typ.	Max	Unit
Forward voltage	$I_F = 10\text{ mA}$	V_F		1.25	1.5	V
Breakdown voltage	$I_R = 10\text{ }\mu\text{A}$	V_{BR}	6.0			V
Reverse current	$V_R = 6.0\text{ V}$	I_R		0.01	10	μA
Capacitance	$V_R = 0\text{ V}$, $f = 1.0\text{ MHz}$	C_O		25		pF
Thermal resistance		R_{thja}		750		K/W

Output

Parameter	Test condition	Part	Symbol	Min	Typ.	Max	Unit
Collector-emitter capacitance	$V_{CE} = 5.0\text{ V}$, $f = 1.0\text{ MHz}$		C_{CE}		5.2		pF
Collector-emitter dark current	$V_{CE} = 10\text{ V}$, $T_A = 25\text{ }^{\circ}\text{C}$	MOC8101	I_{CEO1}		1.0	50	nA
	$V_{CE} = 10\text{ V}$, $T_A = 100\text{ }^{\circ}\text{C}$	MOC8102	I_{CEO1}		1.0		μA
Collector-emitter breakdown voltage	$I_C = 1.0\text{ mA}$		BV_{CEO}	30			V
Emitter-collector breakdown voltage	$I_E = 100\text{ }\mu\text{A}$		BV_{ECO}	7.0			V
Thermal resistance			R_{thja}		500		K/W

Coupler

Parameter	Test condition	Symbol	Min	Typ.	Max	Unit
Saturation voltage collector-emitter	$I_F = 5.0\text{ mA}$	V_{CEsat}		0.25	0.4	V
Coupling capacitance		C_C		0.6		pF

Current Transfer Ratio

Parameter	Test condition	Part	Symbol	Min	Typ.	Max	Unit
Current Transfer Ratio	$V_{CE} = 10\text{ V}$, $I_F = 10\text{ mA}$	MOC8101	CTR	50		80	%
		MOC8102	CTR	73		117	%
		MOC8103	CTR	108		173	%
		MOC8104	CTR	160		256	%
		MOC8105	CTR	65		133	%

Switching Characteristics

Parameter	Test condition	Symbol	Min	Typ.	Max	Unit
Turn-on time	$V_{CC} = 10\text{ V}$, $I_C = 2.0\text{ mA}$, $R_L = 100\ \Omega$	t_{on}		3.0		μs
Turn-off time	$V_{CC} = 10\text{ V}$, $I_C = 2.0\text{ mA}$, $R_L = 100\ \Omega$	t_{off}		2.3		μs
Rise time	$V_{CC} = 10\text{ V}$, $I_C = 2.0\text{ mA}$, $R_L = 100\ \Omega$	t_r		2.0		μs
Fall time	$V_{CC} = 10\text{ V}$, $I_C = 2.0\text{ mA}$, $R_L = 100\ \Omega$	t_f		2.0		μs
Cut off frequency		f_{co}		250		kHz

Typical Characteristics ($T_{amb} = 25\text{ }^\circ\text{C}$ unless otherwise specified)

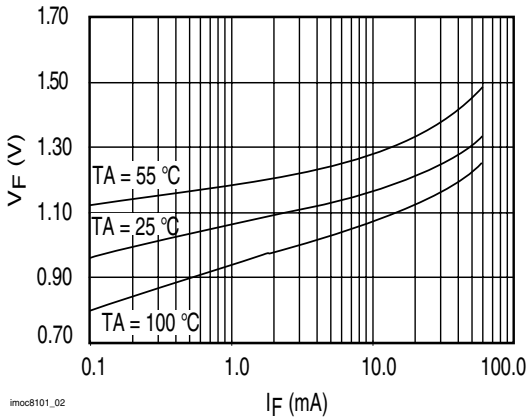

Figure 1. Forward Voltage vs. Forward Current

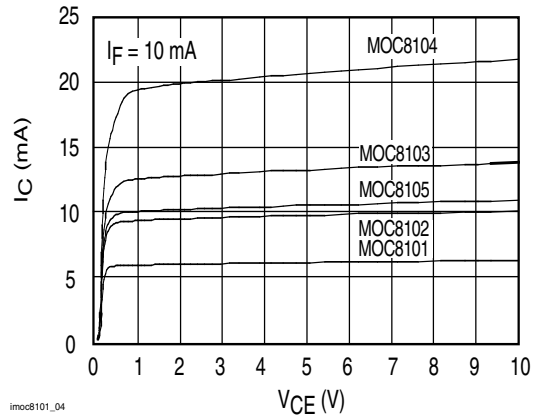

Figure 3. Collector Current vs. Collector Emitter Voltage

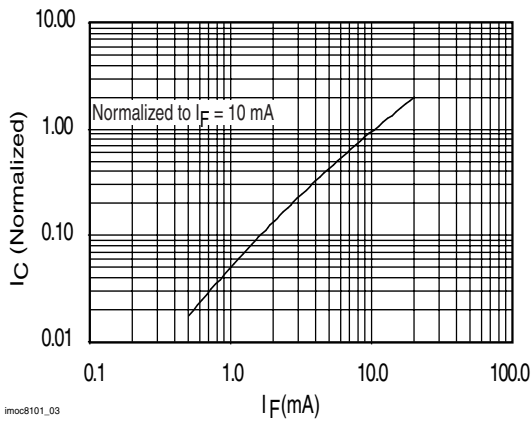

Figure 2. Collector Current vs. LED Forward Current

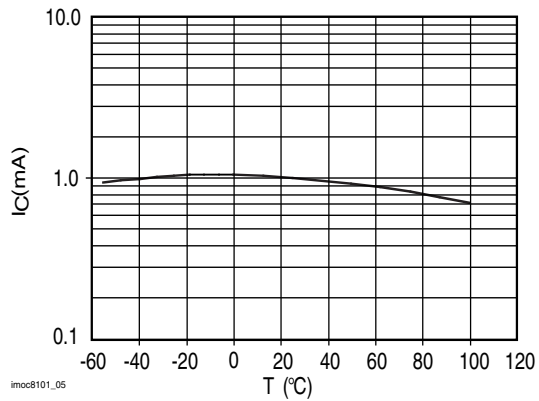

Figure 4. Collector Current vs. Ambient Temperature

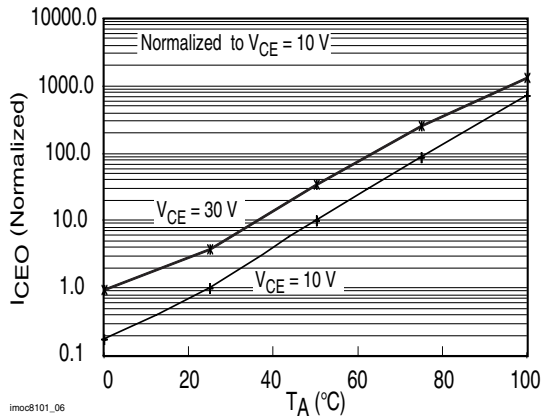

Figure 5. Collector-Emitter Dark Current vs. Ambient Temperature

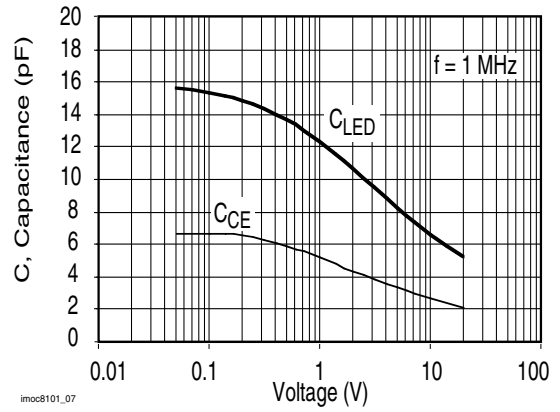

Figure 6. Capacitance vs. Voltage

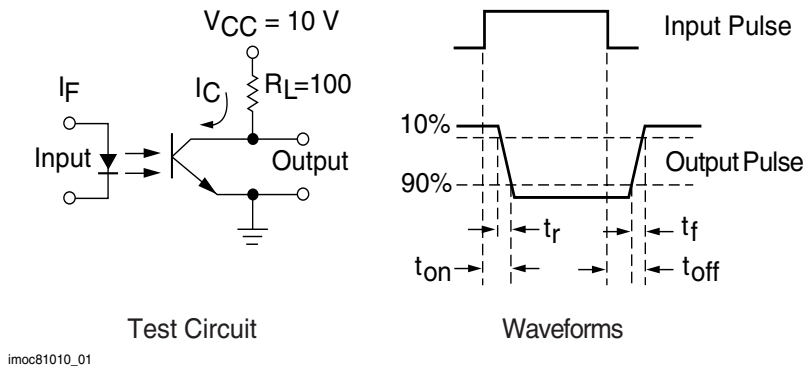

Figure 7. Switching Time Test Circuit and Waveforms

MOC8101/ 2/ 3/ 4/ 5



Vishay Semiconductors

Package Dimensions in Inches (mm)

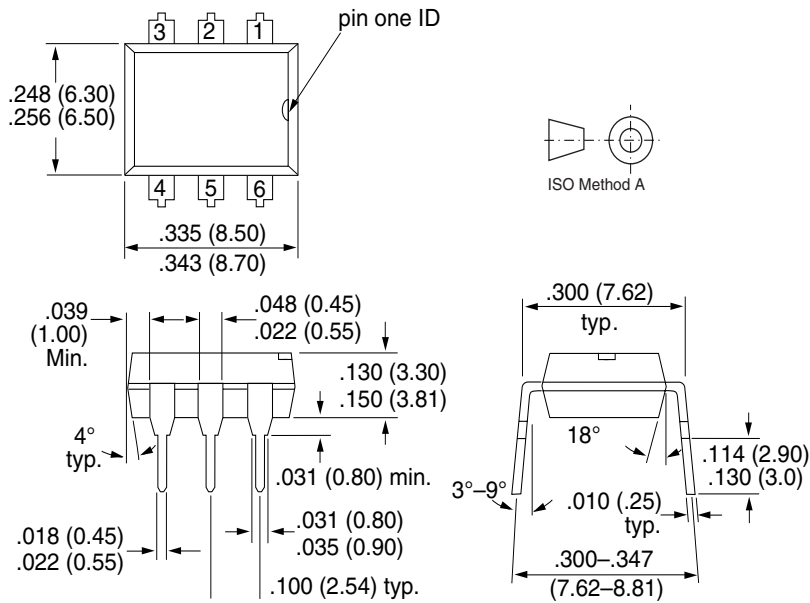

i178004

Option 6

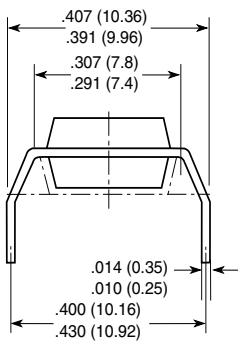

Option 7

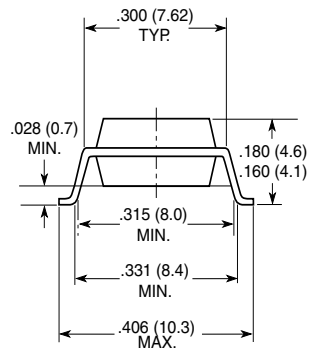

Option 9

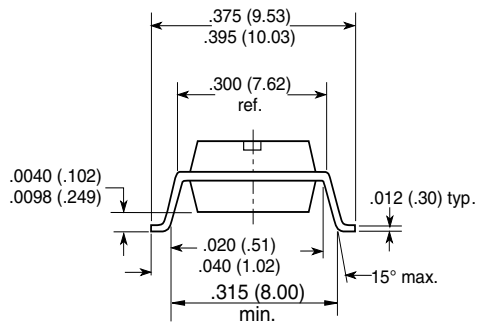

18450



Ozone Depleting Substances Policy Statement

It is the policy of Vishay Semiconductor GmbH to

1. Meet all present and future national and international statutory requirements.
2. Regularly and continuously improve the performance of our products, processes, distribution and operating systems with respect to their impact on the health and safety of our employees and the public, as well as their impact on the environment.

It is particular concern to control or eliminate releases of those substances into the atmosphere which are known as ozone depleting substances (ODSs).

The Montreal Protocol (1987) and its London Amendments (1990) intend to severely restrict the use of ODSs and forbid their use within the next ten years. Various national and international initiatives are pressing for an earlier ban on these substances.

Vishay Semiconductor GmbH has been able to use its policy of continuous improvements to eliminate the use of ODSs listed in the following documents.

1. Annex A, B and list of transitional substances of the Montreal Protocol and the London Amendments respectively
2. Class I and II ozone depleting substances in the Clean Air Act Amendments of 1990 by the Environmental Protection Agency (EPA) in the USA
3. Council Decision 88/540/EEC and 91/690/EEC Annex A, B and C (transitional substances) respectively.

Vishay Semiconductor GmbH can certify that our semiconductors are not manufactured with ozone depleting substances and do not contain such substances.

We reserve the right to make changes to improve technical design and may do so without further notice.

Parameters can vary in different applications. All operating parameters must be validated for each customer application by the customer. Should the buyer use Vishay Semiconductors products for any unintended or unauthorized application, the buyer shall indemnify Vishay Semiconductors against all claims, costs, damages, and expenses, arising out of, directly or indirectly, any claim of personal damage, injury or death associated with such unintended or unauthorized use.

Vishay Semiconductor GmbH, P.O.B. 3535, D-74025 Heilbronn, Germany
Telephone: 49 (0)7131 67 2831, Fax number: 49 (0)7131 67 2423