

记号 MARK	变更号 ECN NO:	核准 APPROVE

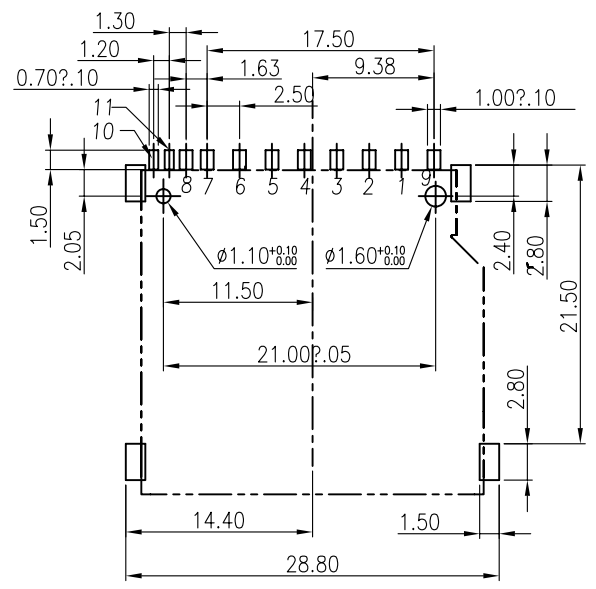

- NOTES:
- MATERIAL
HOUSING: HIGH TEMPERATURE THERMOPLASTIC.
CONTACT: COPPER ALLOY.
SHELL: COPPER ALLOY.
 - PLATING
CONTACT AREA: GOLD PLATED OVER Ni.
SOLDER TAIL: 100 u" MIN Sn PLATED OVER Ni.
SPEC SEE ORDERING INFORMATION
SHELL SOLDER AREA: GOLD PLATED OVER Ni.
 - RATING
CURRENT RATING: 0.5A
VOLTAGE RATING: 250VRM
OPERATING TEMPERATURE: -25°C~90°C
 - SPECIFICATION
CONTACT RESISTANCE: 100mΩMax
DIELECTRIC WITHSTANDING VOLTAGE: 500VAC
INSULATION RESISTANCE: 100 MΩMin
INSERTION FORCE: 40N MAX.
SEPARATION FORCE: 2N MIN.

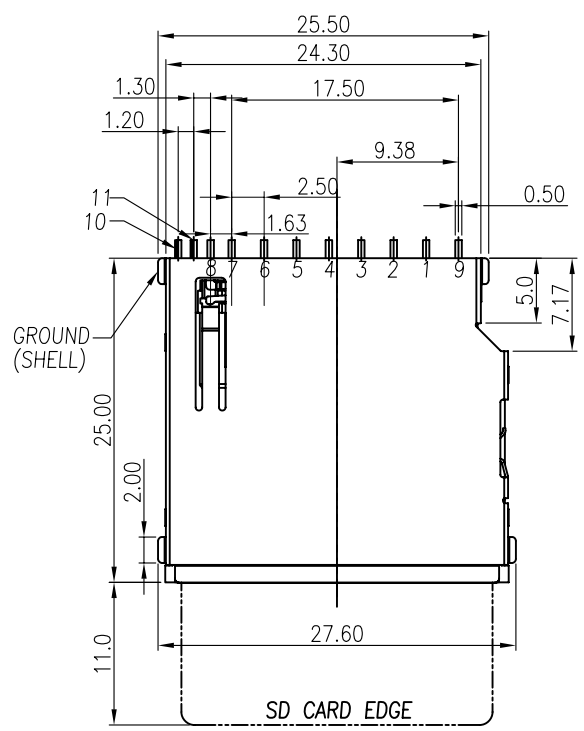
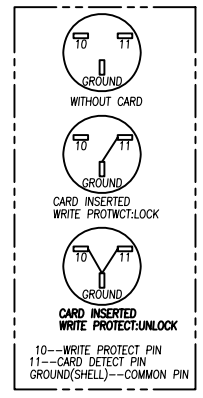
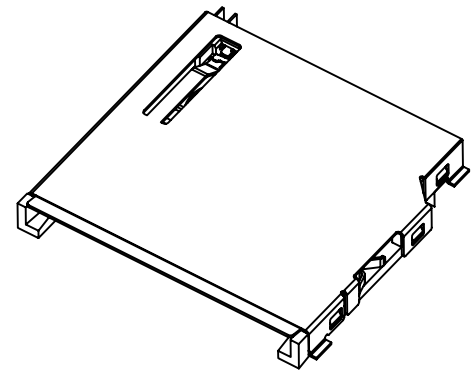
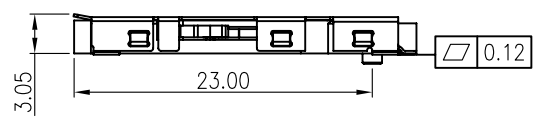
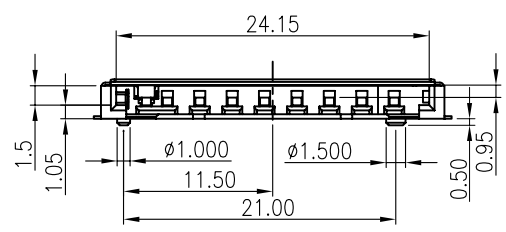

SD CARD PIN DESIGN

Pin No.	Name	Description
1#	CD/DAT3	Card detect/Data I/O
2#	CMD	Command
3#	VSS1	Ground
4#	VDD	Power
5#	CLK	Clock
6#	VSS2	Ground
7#	DAT0	Data I/O
8#	DAT1	Data I/O
9#	DAT2	Data I/O

TOLERANCE .XXX±.10; .XX±.25 .X±.38; ANG±3°	单位 UNIT	mm	深圳市博诚电子实业有限公司 SHENZHEN BOCHENG ELECTRON INDUSTRY CO., LTD		
THE PROPERTY OF BC PRECISION IND. THESE DRAWINGS AND SPECIFICATIONS ARE CO., LTD. AND SHALL NOT BE REPRODUCED, COPIED OR USED IN ANY MANNER WITHOUT THE PRIO BC PRECISION IND. CO., LTD.	日期 DATE	08.02.15	图号 DWG NO	PSDBT0-11GLBXXX3-AA	
	制图 DRAWIN	Fire-day	名称 TITLE	SECURE DIGITAL CARD CONNECTOR NORML TYPE	
	审核 CHECKED		页码 SHEET	1/2	版本 REV.
	核准 APPROVE		比例 SCALE	1:1	角法 PROJ.
	比例 SCALE	1:1	角法 PROJ.		组 装 图